

**TYPICAL P.C. CONCRETE SECTION**  
 WESTERN AVE. STA. 7+84.45 TO STA. 58+86.81  
 178TH STREET STA. 98+39.35 TO STA. 101+67.20

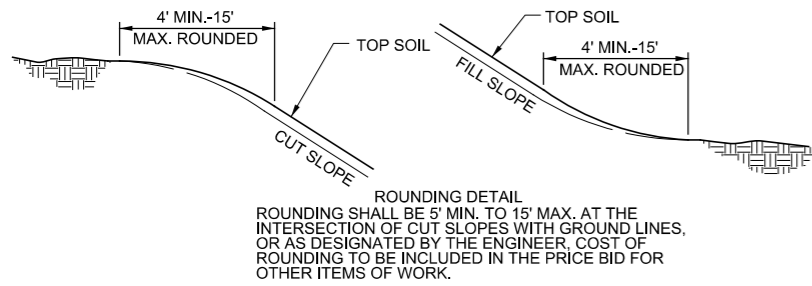

**ROUNDING DETAIL**  
 ROUNDING SHALL BE 5' MIN. TO 15' MAX. AT THE INTERSECTION OF CUT SLOPES WITH GROUND LINES, OR AS DESIGNATED BY THE ENGINEER. COST OF ROUNDING TO BE INCLUDED IN THE PRICE BID FOR OTHER ITEMS OF WORK.

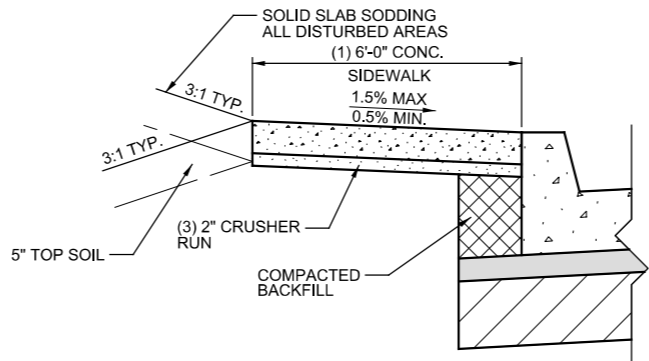

**TYPICAL SIDEWALK AT CURB SECTION**

- NOTES:**
- (1) 5'-0" CONCRETE SIDEWALK IS TYPICAL. WIDENS TO 6'-0" CONCRETE SIDEWALK WHEN ABUTTING CURB.
  - (2) 5'-0" DISTANCE IS TYPICAL. DISTANCE MAY VARY BETWEEN 0' TO 5'-0" DEPENDING ON SIDEWALK LOCATION. REFER TO PLAN AND PROFILE AND CROSS SECTION.
  - (3) CRUSHER RUN TO BE INCLUDED IN OTHER ITEMS OF WORK.
  - (4) BACKFILL NOTE: TO BE BACKFILLED AND COMPACTED AS PART OF THE FINISHING OPERATIONS. COST TO BE INCLUDED IN UNCLASSIFIED EXCAVATION.
  - (5) TOPSOIL NOTE: THE CONTRACTOR SHALL STRIP ALL OF THE AVAILABLE TOPSOIL, STOCKPILE IT, AND PLACE IT BACK ON THE SECTION IN ACCORDANCE WITH SECTION 205 OF THE STANDARD SPECIFICATION. RESERVED TOPSOIL SHALL BE SPREAD APPROX. 5" THICK FIRST ON THE COMPLETED SLOPES OF THE CUT SECTIONS AND THE REMAINDER ON COMPLETED FILL SLOPES OR OTHER PRIORITY AREAS LOCATED BY THE ENGINEER. ALL ADDITIONAL COSTS ASSOCIATED WITH OPERATION SHALL BE INCLUDED IN THE PAY ITEM FOR TYPE A-SALVAGED TOPSOIL, LUMP SUM.
- THE GRADING LINE AS SHOWN ON THE TYPICAL AND CROSS SECTIONS IS TO THE TOP OF THE TOPSOIL. EARTHWORK QUANTITIES WERE NOT ADJUSTED FOR SALVAGE.

PRINT DATE: 12/19/2016 T:\1209\Drawings\Roadway\1209-S-yp1.dgn

DESIGN	KG		NORTH WESTERN AVE.	OKLAHOMA CO.
DRAWN	NDA		<b>OKLAHOMA DEPARTMENT OF TRANSPORTATION</b>	
CHECKED	KA			
APPROVED				
SQUAD	MacArthur			
			<b>TYPICAL SECTIONS</b>	
			STATE JOB NO. <u>JP 30326(04)</u> SHEET NO. <u>3</u>	