

X:\Odot\EC-1589B\Struc\Bridge_A\DIAPH-J.dgn

3/2/2017

REV. NO.	DESCRIPTION	REVISIONS	DATE

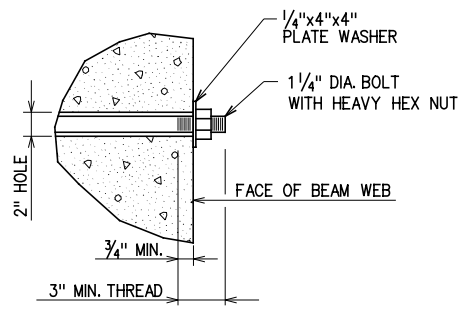
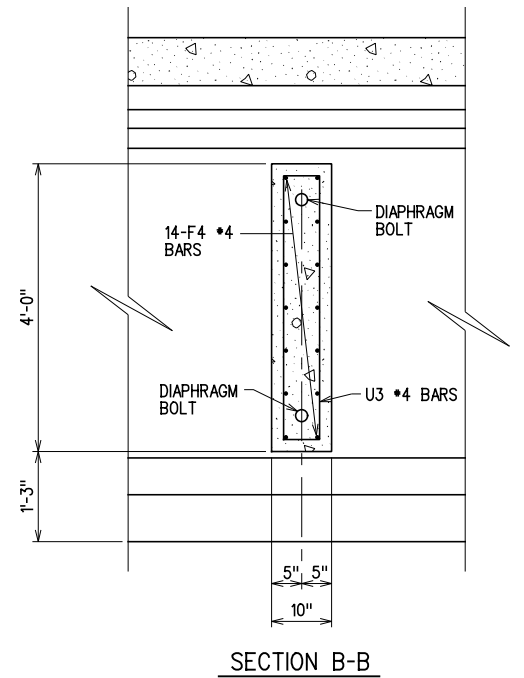
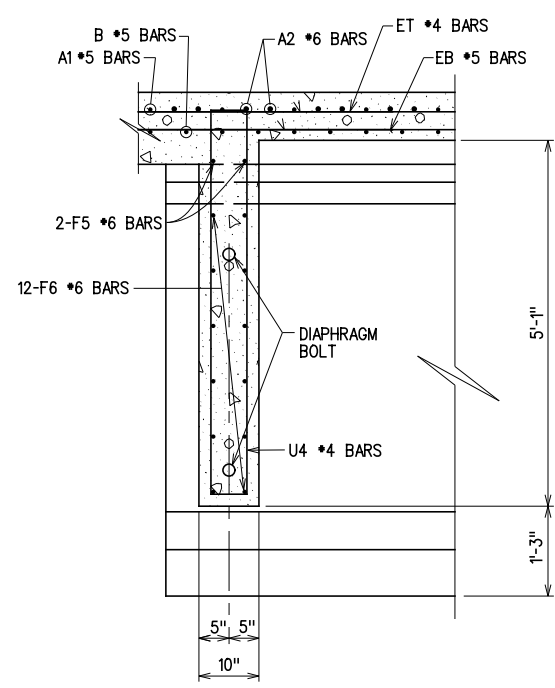
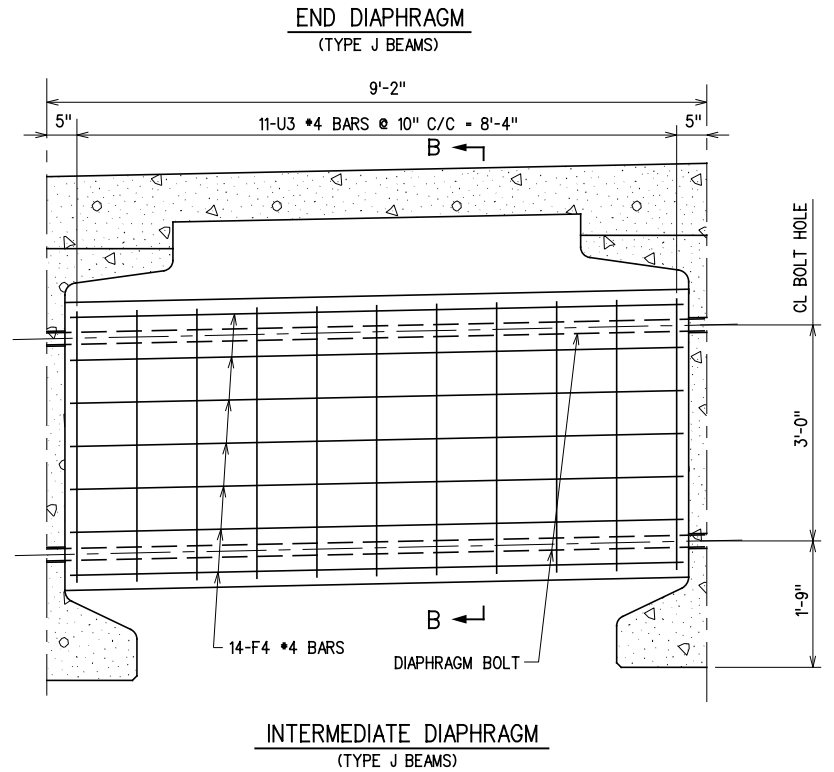
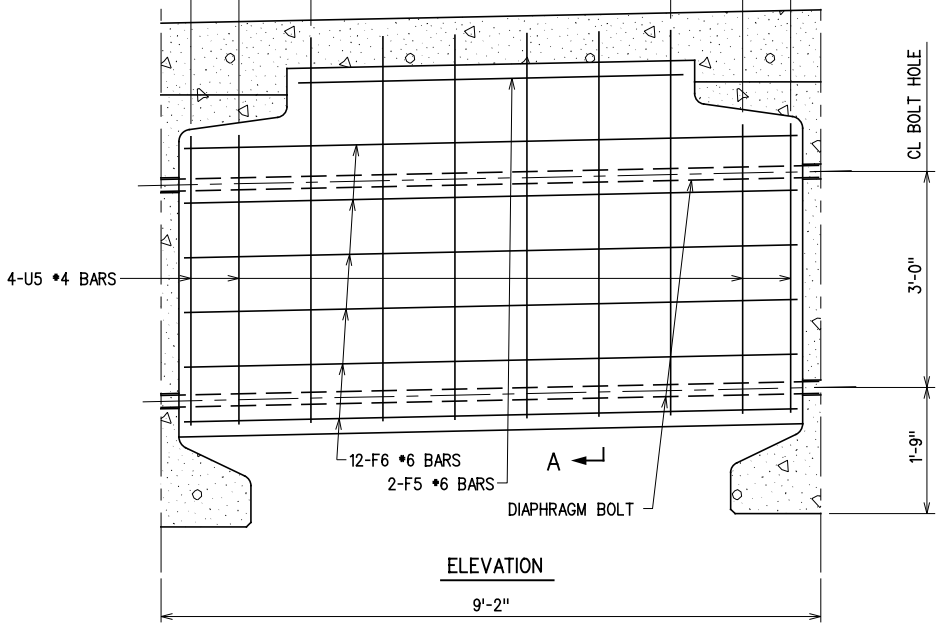
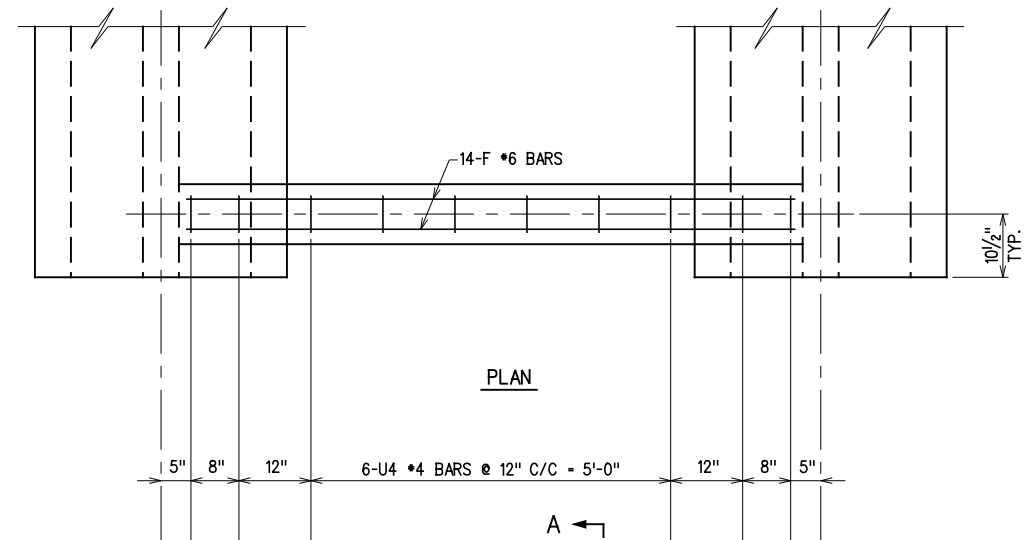

DIAPHRAGM BOLT DETAIL

NOTE:
 STRUCTURAL STEEL FOR DIAPHRAGM BOLTS AND PLATE WASHERS SHALL CONFORM TO AASHTO M270 (ASTM A709), GRADE 50W (WEATHERING STEEL, CHARPY V-NOTCH TESTING NOT REQUIRED). A #10 REINFORCING BAR CONFORMING TO AASHTO M31, GRADE 60, AND THREADED AT THE ENDS AS SHOWN MAY BE SUBSTITUTED FOR THE DIAPHRAGM BOLT AT NO ADDITIONAL COST. HEX NUTS SHALL CONFORM TO AASHTO M291 (ASTM A563).

PAINT EXPOSED DIAPHRAGM BOLT, HEX NUT AND PLATE WASHER WITH TWO COATS OF ZINC RICH PAINT (MIN. 6 MIL THICKNESS) AFTER ASSEMBLY. ALL COST OF DIAPHRAGM BOLT, PLATE WASHER AND HEX NUT TO BE INCLUDED IN THE UNIT PRICE BID FOR "STRUCTURAL STEEL"

TYPE J BEAMS		ROCK CRUSHER RD. OVER I-35	MURRAY COUNTY
DESIGN		BRIDGE "A"	
DRAWN			
CHECKED			
APPROVED			
SQUAD	G/K ENGR.	JOB PIECE NO. 30363(04)	SHEET NO. 74

DIAPHRAGM DETAILS
 (2 OF 2)