

**1 SH 10 TYPICAL SECTION**  
 STA. 1433+40.00 TO STA. 1436+64.15 N.T.S.  
 STA. 1439+34.65 TO STA. 1443+30.00

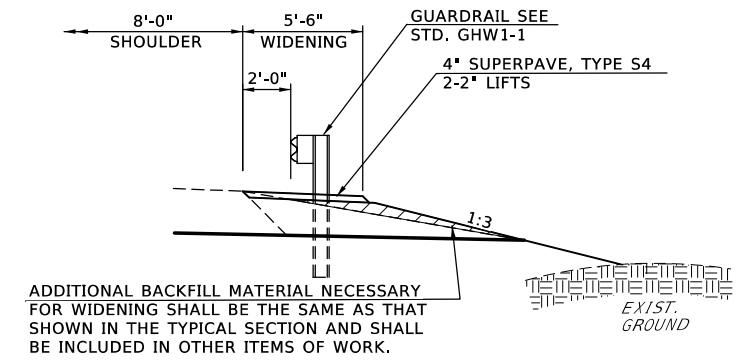

**GUARDRAIL DETAIL**  
 N.T.S.  
 STA. 1434+71.00 TO STA. 1436+64.75 RT.  
 STA. 1434+33.50 TO STA. 1436+64.75 LT.(OPPOSITE HAND)  
 STA. 1439+34.05 TO STA. 1440+77.80 RT.  
 STA. 1439+34.05 TO STA. 1442+52.80 LT.(OPPOSITE HAND)

- 1 PERMANENT SLOPE PROTECTION**  
REFER TO DETAIL SHEET 3.
  - 2 BACKFILL NOTE:**  
TO BE BACKFILLED & COMPACTED AS PART OF THE FINISHING OPERATIONS. QUANTITY IS MEASURED IN TBSC TYPE E.
  - 3 FILL SLOPE DEPTHS ARE DEFINED**  
FROM EDGE OF SHOULDER.
  - 4 TOPSOIL NOTE :**  
THE CONTRACTOR SHALL STRIP ALL OF THE AVAILABLE TOPSOIL, STOCKPILE IT AND PLACE IT BACK ON THE SECTION IN ACCORDANCE WITH SECTION 205 OF THE STANDARD SPECIFICATIONS. RESERVED TOPSOIL SHALL BE SPREAD FIRST ON THE COMPLETE SLOPES OF THE CUT SECTIONS AND THE REMAINDER ON COMPLETED FILL SLOPES OR OTHER PRIORITY AREAS LOCATED BY THE ENGINEER. ALL ADDITIONAL COSTS ASSOCIATED WITH OPERATION SHALL BE INCLUDED IN THE PAY ITEMS FOR SALVAGED TOPSOIL, LUMP SUM.
- THE GRADING LINE AS SHOWN ON THE TYPICAL AND CROSS SECTIONS IS TO THE TOP OF THE TOPSOIL. EARTHWORK QUANTITIES WERE NOT ADJUSTED FOR SALVAGE AND THE TOPSOIL QUANTITY IS INCLUDED IN THE SUMMARIZED EARTHWORK.
- THE GRADING LINE AS SHOWN ON THE TYPICAL AND CROSS SECTIONS IS TO TOP OF THE SOIL. EARTHWORK QUANTITIES WERE NOT ADJUSTED FOR SALVAGE AND TOPSOIL QUANTITY IS INCLUDED IN THE SUMMARIZED EARTHWORK.

|          |  |                            |              |
|----------|--|----------------------------|--------------|
| Design   |  | SH 10 OVER BIG CABIN CREEK | CRAIG COUNTY |
| Drawn    |  | <b>TYPICAL SECTIONS</b>    |              |
| Checked  |  |                            |              |
| Approved |  |                            |              |
| Squad    |  |                            |              |
|          |  | State Job No. 29068(04)    | Sheet No. 2  |