

TYPICAL MOUNTING DETAILS FOR PEDESTAL MOUNTED SLIP FITTER SIGNAL

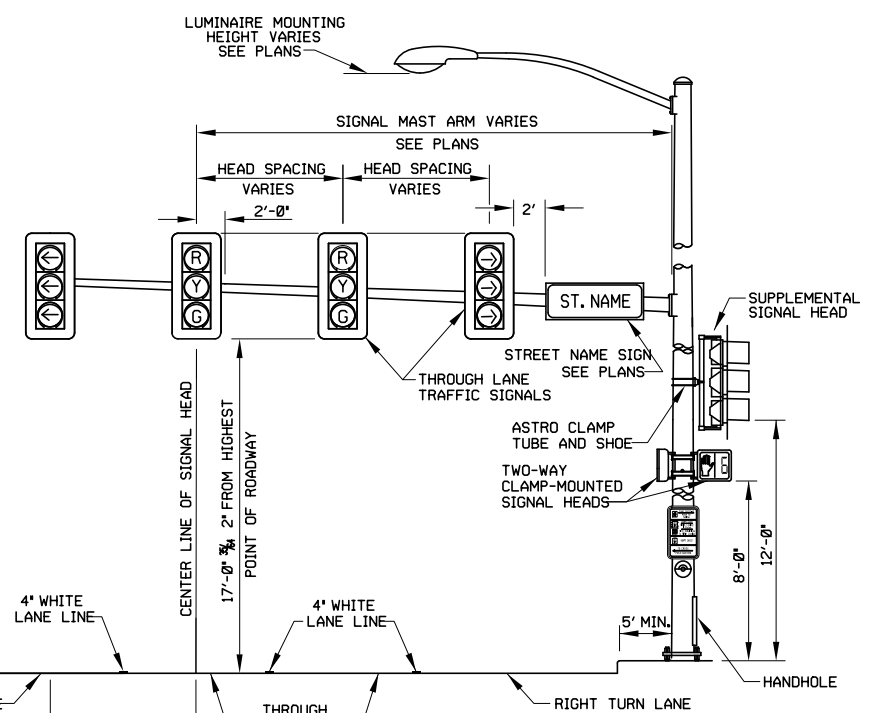

TYPICAL SIGNAL EQUIPMENT PLACEMENT WITH PROTECTED ONLY HEADS

- NOTE:**
- PULL BOX LOCATIONS SHALL BE OUTSIDE OF WHEELCHAIR RAMPS AND WHEEL DRAG PATH.
 - SIGNAL HEAD, PEDESTRIAN HEAD, AND PEDESTRIAN PUSH BUTTON PLACEMENT TO BE APPROVED BY THE TRAFFIC ENGINEER PRIOR TO INSTALLATION.

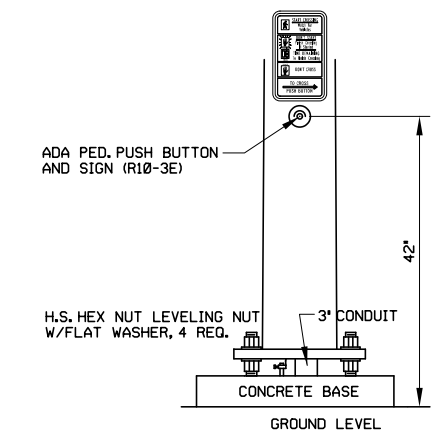

TYPICAL MOUNTING DETAILS FOR MAST ARM POLE

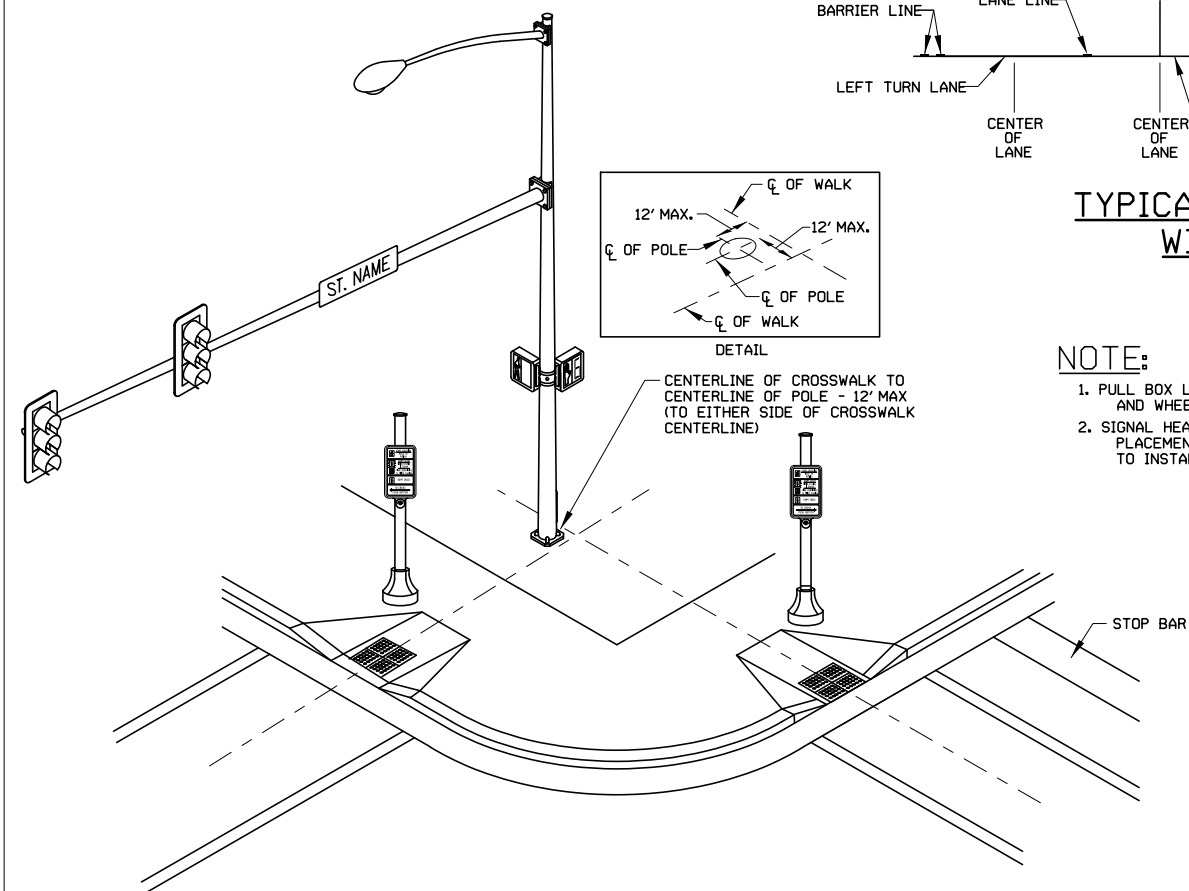

TYPICAL SIGNAL POLE PLACEMENT FOR PEDESTRIAN CROSSWALKS

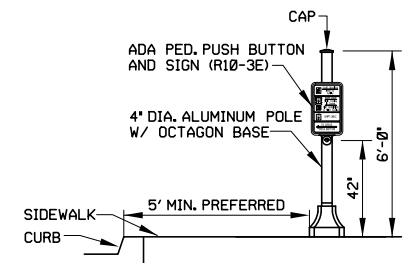

TYPICAL MOUNTING DETAILS FOR PEDESTRIAN PUSH BUTTON POLE

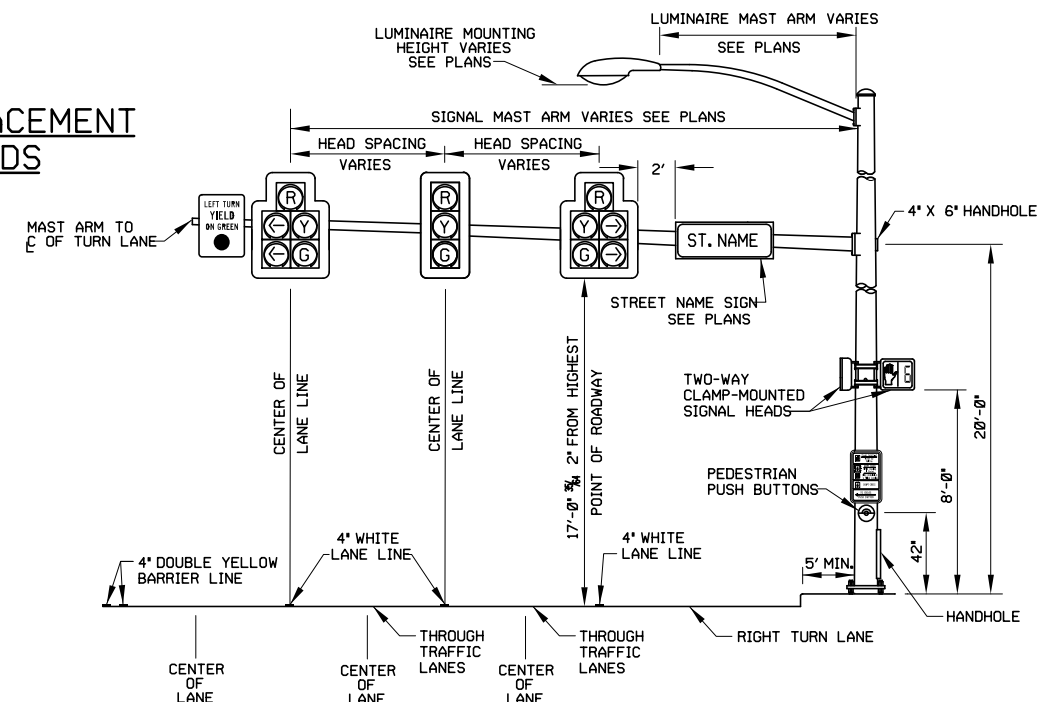

TYPICAL SIGNAL EQUIPMENT PLACEMENT WITH PROTECTED/PERMISSIVE HEADS

BEFORE YOU DIG
CALL OKIE
811



JACOBS
10816 EXECUTIVE CENTER DR. STE. 300
LITTLE ROCK, ARKANSAS 72211

DESIGN	BLV	OKLAHOMA DEPARTMENT OF TRANSPORTATION DESIGN DIVISION PEDESTAL AND MAST ARM POLE DETAILS STD. 613 PROJECT NO. 23708(06) SHEET NO. 52
DRAWN	JAB	
CHECKED	BLV	
APPROVED	BLV	
SQUAD	Jacobs	