

SECTION VIEW OF DETECTOR WIRE THROUGH EXISTING CURB TO PULL BOX

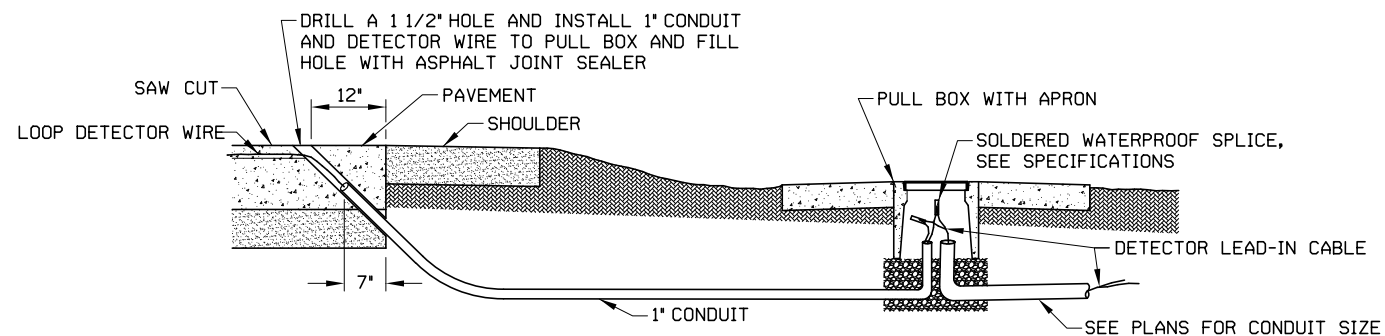

SECTION VIEW OF DETECTOR WIRE THROUGH PAVEMENT TO PULL BOX

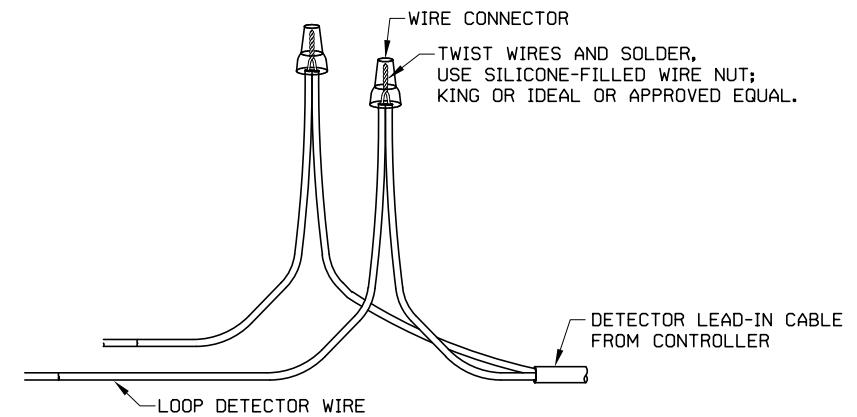

LOOP DETECTOR WIRE CONNECTION DETAIL

BEFORE YOU DIG  
CALL OKIE  
811



**JACOBS**

10816 EXECUTIVE CENTER DR. STE. 300  
LITTLE ROCK, ARKANSAS 72211

|          |        |  |
|----------|--------|--|
| DESIGN   | BLV    | <b>OKLAHOMA DEPARTMENT OF TRANSPORTATION<br/>DESIGN DIVISION</b><br><br>DETECTOR WIRE INSTALLATION STD. 604B<br><br>PROJECT NO. 23708(06) SHEET NO. 44 |
| DRAWN    | JAB    |  |
| CHECKED  | BLV    |  |
| APPROVED | BLV    |  |
| SQUAD    | Jacobs |  |