









BA Expy Off Ramp

BA Expy

LEGEND - SYMBOLS

-  EXISTING POLE AND BASE
-  PROPOSED POLE AND BASE
-  TRAFFIC PULLBOX
-  SIGNAL CABINET
-  FIRE HYDRANT
-  UTILITY POLE
-  SIGNAL HEAD (TYPE INDICATED)
-  CONDUIT WITH CONDUCTOR
-  LUMINAIRE

NOTE ON POLE LOCATION:
 DESIGNATION SHOWN FOR EACH POLE IS THE
 OFFSET FROM CURBLINE TO CENTER OF POLE:
 -1ST NUMBER IS OFFSET FROM EAST-WEST CURBLINE
 -2ND NUMBER IS OFFSET FROM NORTH-SOUTH CURBLINE

LEGEND - ITEMS OF WORK

- (A) REMOVE POLE AND BASE
- (B) INSTALL POLE AND BASE
- (C) INSTALL CONDUIT AND CONDUCTOR
(2"/20-C, UNLESS NOTED OTHERWISE)
- (D) REPLACE OR INSTALL PULLBOX
(TYPE 2, UNLESS NOTED OTHERWISE)
- (E) REMOVE AND REPLACE SIDEWALK

Pole 'C'
2.7' / 22.0'

Pole 'B'
3.5' / 3.5'

Pole 'C'
3.0' / 6.1'

Pole 'A'
2.2' / N/A

N. Harvard Ave.

SIDEWALK

OFF
SIDEWALK

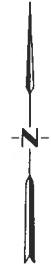
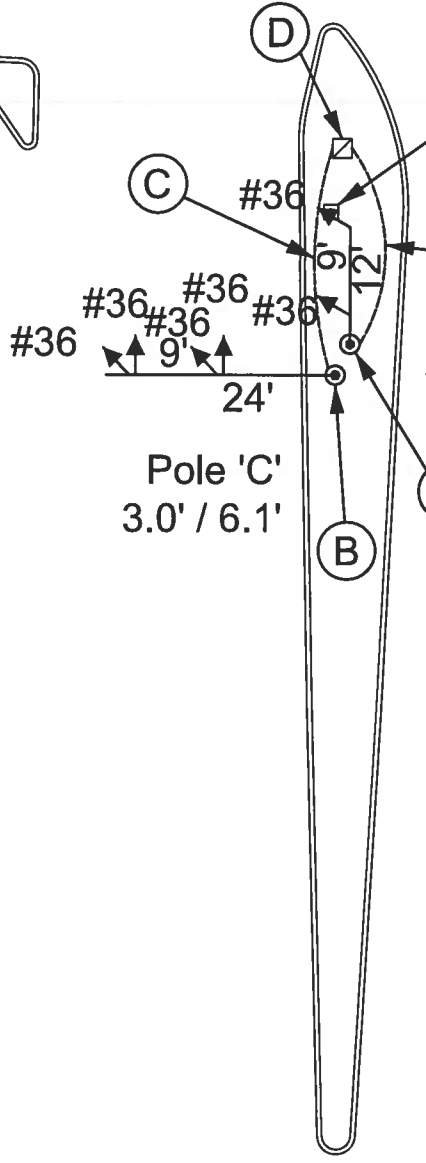

BEFORE YOU DIG
CALL OKIE
811

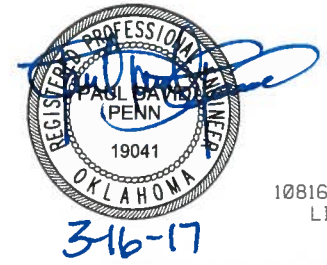

JACOBS
 10816 EXECUTIVE CENTER DR. STE. 300
 LITTLE ROCK, ARKANSAS 72211

DESIGN	BLV		OKLAHOMA DEPARTMENT OF TRANSPORTATION DESIGN DIVISION TULSA TRAFFIC SIGNAL LED UPGRADE PROJECT REPLACEMENT PLAN (BA EXPY & HARVARD AVE. SOUTH) PROJECT NO. 23708(06) SHEET NO. 31
DRAWN	JAB		
CHECKED	BLV		
APPROVED	BLV		
SQUAD	Jacobs		