

APPROACH SLAB NO. 1

APPROACH SLAB NO. 2

② SAWED AND SEALED CONSTRUCTION JOINT
(SEE "GENERAL PLAN AND TYPICAL CROSS SECTION" (BRIDGE "A") FOR DETAIL)

BAR LIST - APPROACH SLABS (PHASE 1)					
MARK	NO.	SIZE	FORM	LENGTH	VARIANCE
EPOXY COATED					
AT1	116	#4	STR.	19'-8"	---
AT2	3	#4	STR.	7'-11" Avg.	1'-0" to 14'-10"
AT3	6	#4	STR.	8'-8" Avg.	1'-9" to 15'-7"
AT4	3	#4	STR.	9'-5" Avg.	2'-6" to 16'-4"
AT5	4	#4	STR.	19'-10"	---
AT6	55	#4	STR.	39'-10"	---
AT7	6	#4	STR.	18'-5 1/2" Avg.	1'-2" to 35'-9"
AT8	2	#4	STR.	40'-0"	---
AT9	6	#4	STR.	19'-2 1/2" Avg.	1'-11" to 36'-6"
AL1	21	#4	STR.	32'-8" Avg.	31'-3" to 34'-1"
AL2	42	#4	STR.	26'-3 1/2" Avg.	21'-4" to 31'-3"
AL3	21	#4	STR.	26'-11" Avg.	25'-6" to 28'-4"
AL4	61	#9	STR.	31'-2 1/2" Avg.	28'-4" to 34'-1"
AL6	61	#9	STR.	28'-4 1/2" Avg.	25'-6" to 31'-3"

BAR LIST - APPROACH SLABS (PHASE 2)					
MARK	NO.	SIZE	FORM	LENGTH	VARIANCE
EPOXY COATED					
AT1	116	#4	STR.	19'-8"	---
AT2	6	#4	STR.	7'-11" Avg.	1'-0" to 14'-10"
AT4	6	#4	STR.	9'-5" Avg.	2'-6" to 16'-4"
AT5	4	#4	STR.	19'-10"	---
AL1	21	#4	STR.	32'-8" Avg.	31'-3" to 34'-1"
AL3	21	#4	STR.	26'-11" Avg.	25'-6" to 28'-4"
AL5	31	#9	STR.	26'-11" Avg.	25'-6" to 28'-4"
AL7	31	#9	STR.	32'-8" Avg.	31'-3" to 34'-1"

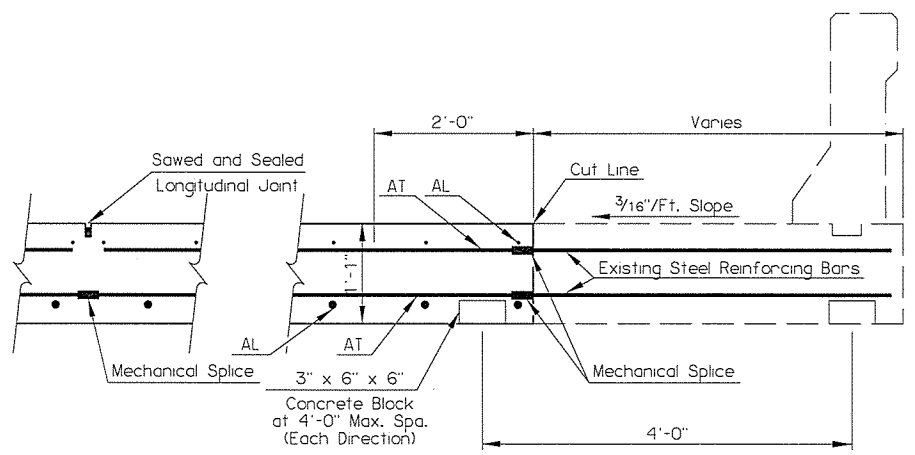

SECTION OF APPROACH SLAB

QUANTITIES - APPROACH SLABS (ONE SHOWN, TWO REQUIRED)		
ITEM	UNIT	TOTAL
Approach Slab	S.Y.	200.00
Saw-Cut Grooving	S.Y.	190.00
Deck Area Sealed (Floodcoat)	S.Y.	225.00
Mechanical Splices	EA.	156.00

① The Department considers the cost of Concrete, Reinforcing Steel, Backer Rod, Rapid Cure Joint Sealant, Polystyrene, and Polyethylene Sheeting to be included in the contract unit price of APPROACH SLAB.
There is an estimated 216.70 C.Y. of Class AA Concrete and an estimated 20,807 LB. of Epoxy Coated Reinforcing Steel in each Approach Slab.

US-169 OVER 51ST NORTHBOUND BRIDGE "A"	TULSA COUNTY	Design N/A N/A
DETAILS OF APPROACHES		Detail RLA 5/15
		Check KMS 6/15
Squad: MAYFIELD Engr. ELYAZGI		
STATE OF OKLAHOMA	DEPARTMENT OF TRANSPORTATION	
JOB PRICE NO. 31672(04)		SHEET NO. B002