

OKLAHOMA DEPARTMENT OF TRANSPORTATION						
FED. ROAD DIST. NO.	STATE	JOB PIECE NO.	FISCAL YEAR	SHEET NO.	TOTAL SHEETS	
6	OKLA.	29773(04)				
DESCRIPTION		REVISIONS			DATE	

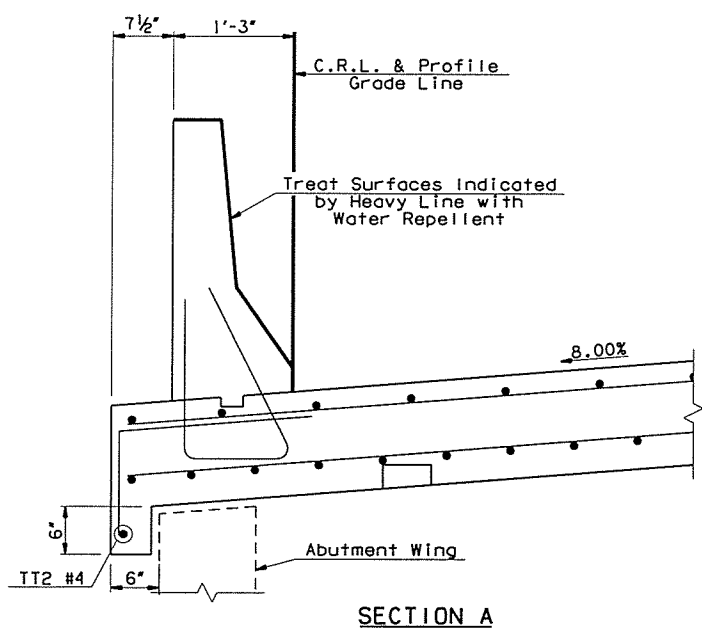

SECTION A

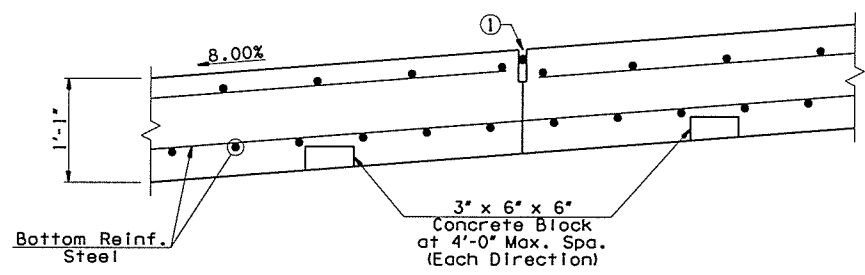

SECTION C THRU APPROACH SLAB

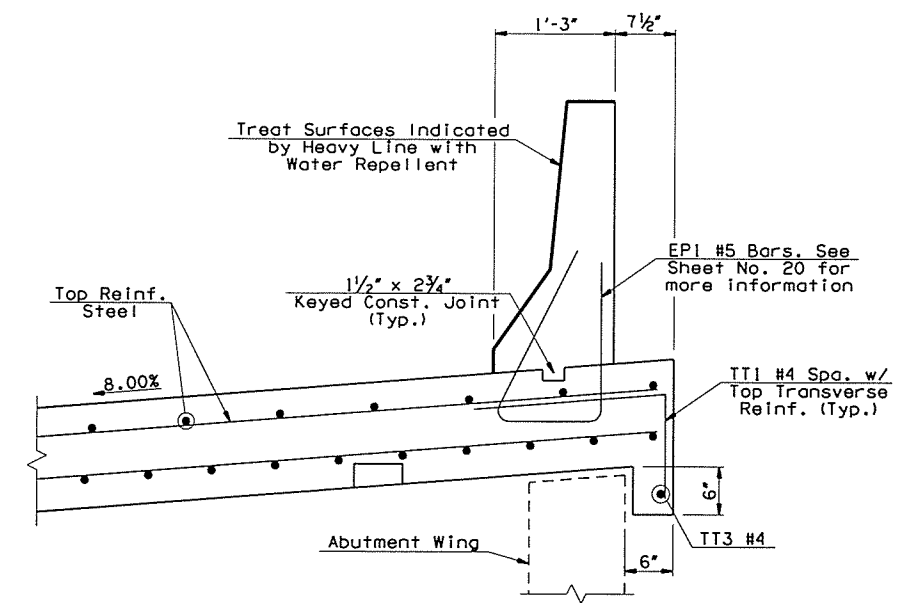

SECTION B

④ ANCHORAGE SYSTEM:

The Contractor shall use an Anchorage System that has been approved by ODOT's materials division. The Anchorage System shall be capable of developing the full strength of the reinforcing steel that is to be anchored. The embedment depth shown is to be adjusted in accordance with the Manufacturer's specifications for the system used.

Drilling into the existing concrete to install the anchorage shall be accomplished without cutting existing concrete reinforcing steel bars. Prior to drilling, the Contractor shall locate and mark the existing concrete reinforcing steel bars with non-destructive tools, equipment and methods approved by the Engineer. If existing reinforcing steel bars are encountered during drilling, the drilling shall cease and the hole shall be grouted. The hole shall then be relocated to clear the existing reinforcing steel bars. Any adjustment in the locations of the new DB1 Bars from the plan locations shown shall be the minimum amount necessary to avoid cutting the existing concrete reinforcing steel bars and shall be approved by the Engineer.

All costs of the Anchorage Assemblies including labor, materials, tools, drilling, and incidentals necessary to complete the work shown in the plans shall be included in the price bid per Square Yard of "APPROACH SLAB".

- ① 1/2" Longitudinal Sawn and Sealed Joint in the top of Approach Slab (See DETAIL "A").
- ② 2" Expansion Joint between Approach Slab and Deck Slab, see Sheet No. 18 for Expansion Joint Opening Equation.

NOTES:
Do not groove within 6" of any joint.
Place reinforcing steel in the top of the Approach Slab 2" from either side of the Sawn & Sealed Longitudinal Joints.
See Sheet No. 20 for parapet reinforcing.

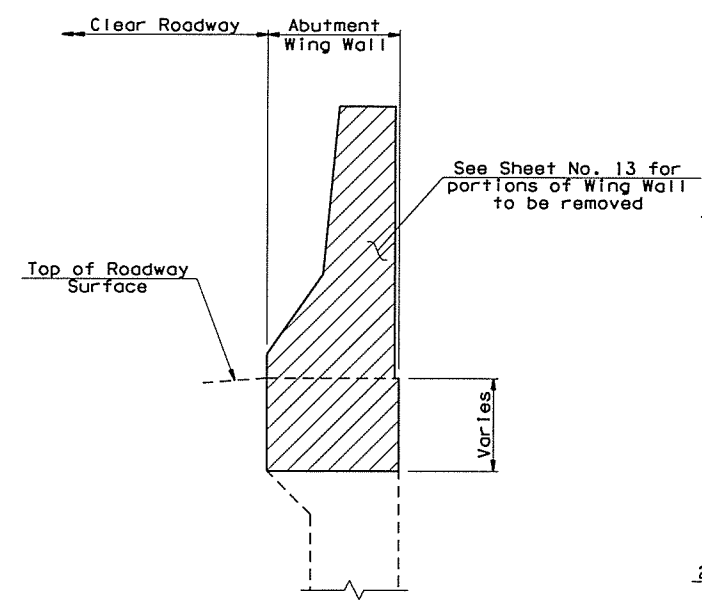

EXISTING CONDITIONS AT WINGWALL

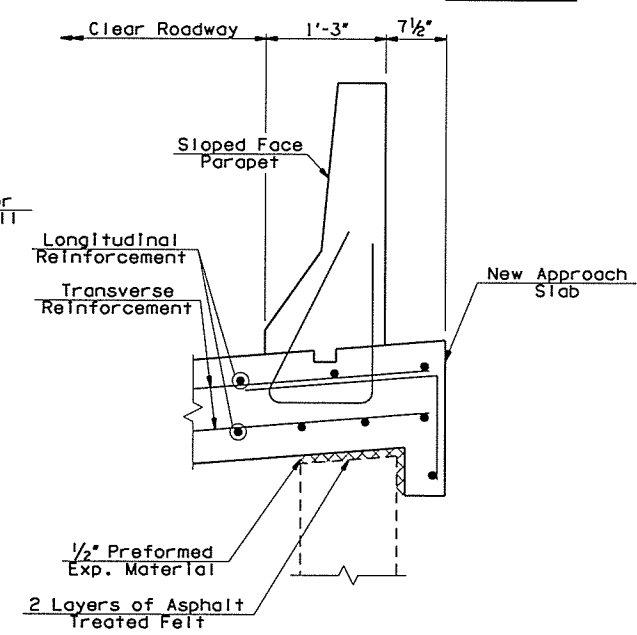

NEW APPROACH SLAB AT ABUTMENT WING

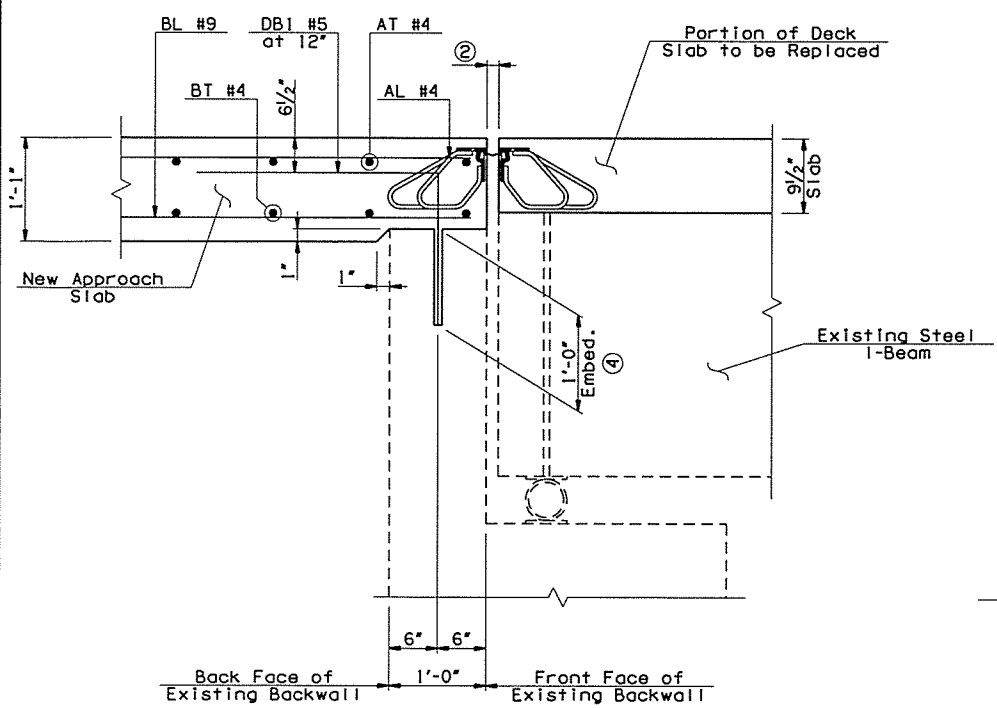

SECTION D-D

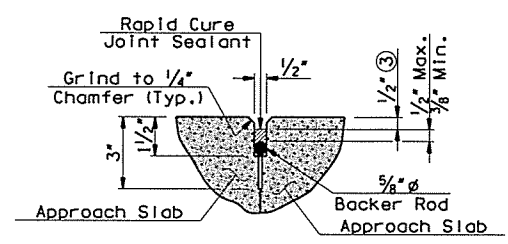

DETAIL "A"

③ This dimension shall taper from 1/2" at edge of driving lane/shoulder to 1/8" at rail for Transverse Joints only.

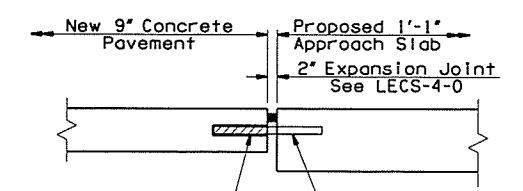

DETAIL "B"

Exposed 9" of Dowel Bar shall be coated with form release agent or grease before Expansion Cap is installed to insure that the bond between Dowel Bar and Concrete Pavement is broken.

Dowel Bars shall be epoxied (non-capped end) into 1 1/8 inch (max.) by 9" deep drilled holes, spaced at 1'-0" centers, placed at mid-slab. Drilled holes and Dowel Bars shall be placed parallel to the driving surface. Sufficient epoxy shall be used to completely fill the void between the Dowel Bar and the hole.

NOTES:
All costs of installation of Terminal Joint, including dowel bars, epoxy, expansion joint, materials, labor, equipment, and any incidentals necessary to complete the work as shown shall be included in "APPROACH SLAB".
For details of dowel bars, see Std. CRCP2-3-0.

GILCREASE EXPRESSWAY RAMP OVER COUNTY ROAD & BNSF RR BRIDGE "A"		TULSA COUNTY	DESIGN	JTR	4/16
APPROACH SLAB DETAILS (SHEET 2 OF 2)			DETAIL	SJL	4/16
			CHECK	BRT	5/16
			GARVER		
STATE OF OKLAHOMA	DEPARTMENT OF TRANSPORTATION				
	JOB PIECE NO. 29773(04)	SHEET NO. 23			