

TYPICAL SECTION NO. 1

NOT TO SCALE

C.R.L. STA. 329+12.92 TO C.R.L. STA. 329+37.92
 C.R.L. STA. 332+50.08 TO C.R.L. STA. 332+75.08

PAVT. STRUCTURE	DRIVING LANES
SURFACE COURSE	12" DOWEL JOINTED P.C. CONCRETE PAVEMENT
BASE COURSE	12" AGGREGATE BASE, TYPE A

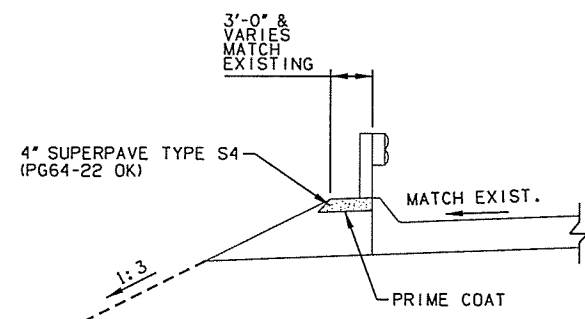

GUARD RAIL WIDENING

NOT TO SCALE

C.R.L. STA. 326+94.17 TO C.R.L. STA. 329+37.92 LT
 C.R.L. STA. 327+44.17 TO C.R.L. STA. 329+37.92 RT
 C.R.L. STA. 332+50.08 TO C.R.L. STA. 333+98.00 RT
 C.R.L. STA. 332+50.08 TO C.R.L. STA. 335+02.60 LT

(1) BACKFILL NOTE:
 TO BE BACKFILLED AND COMPACTED AS PART OF THE FINISHING OPERATIONS.
 QUANTITY IS MEASURED IN OTHER ITEMS OF WORK.

(2) PROPOSED PROFILE GRADE SHALL MEET AND MATCH EXISTING.

DESIGN	MDF	3/16	GILCREASE EXPRESSWAY RAMP OVER COUNTY ROAD & RAILROAD
DRAWN	JWJ	3/16	
CHECKED	KMM	6/16	
APPROVED			
SQUAD	GARVER		

TYPICAL SECTIONS

STATE JOB NO. 29773(04) SHEET NO. 2