

OKLAHOMA DEPARTMENT OF TRANSPORTATION						
FED. ROAD DIST. NO.	STATE	JOB PIECE NO.	FISCAL YEAR	SHEET NO.	TOTAL SHEETS	DATE
X	OKLA.	28872(04)				
DESCRIPTION						REVISIONS

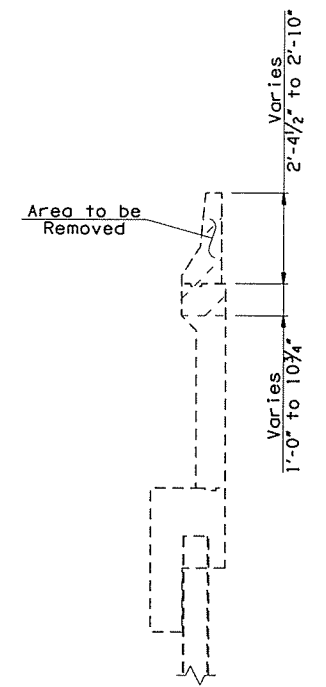
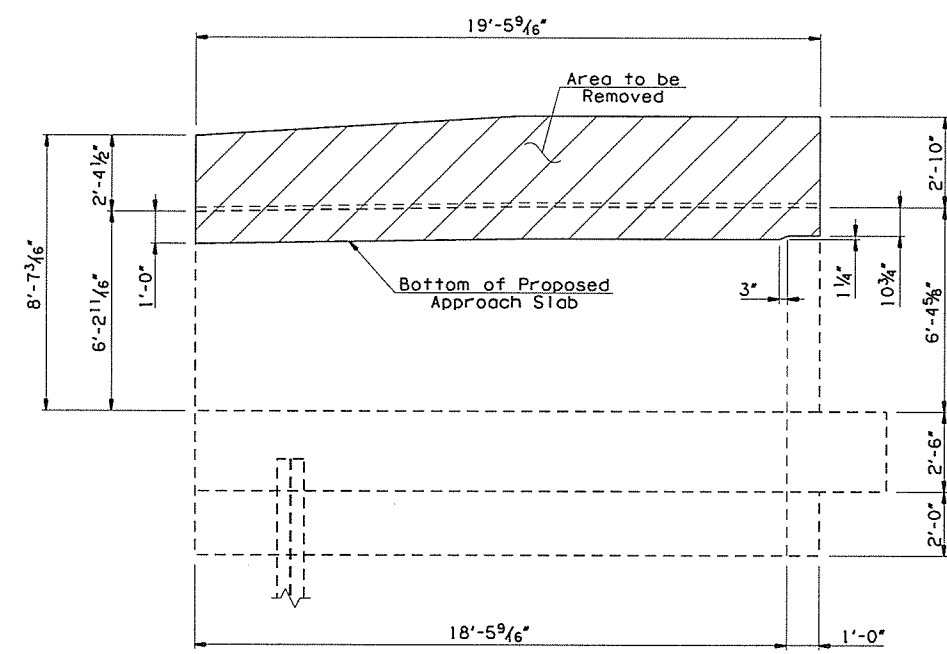
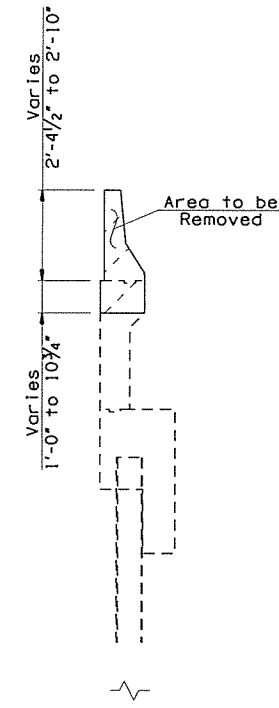
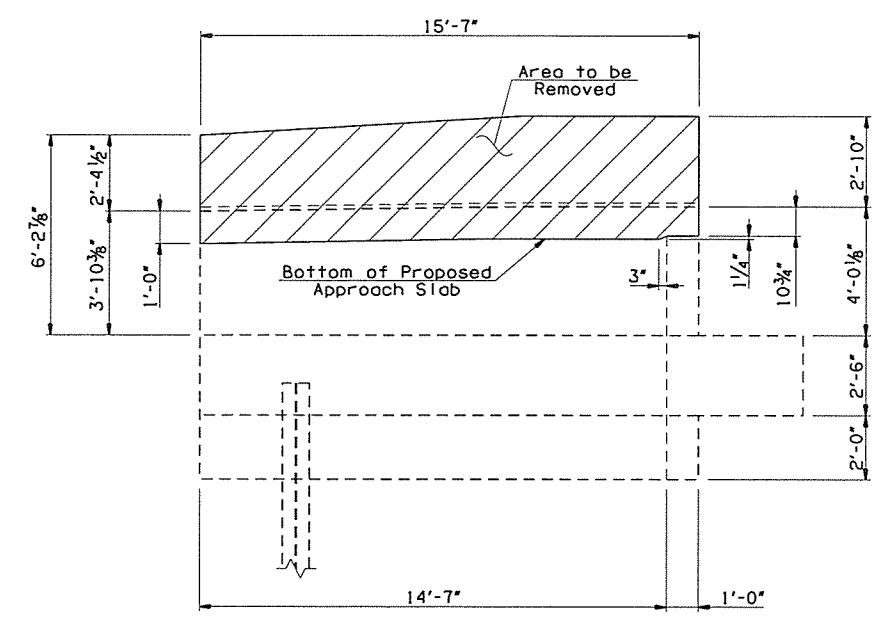
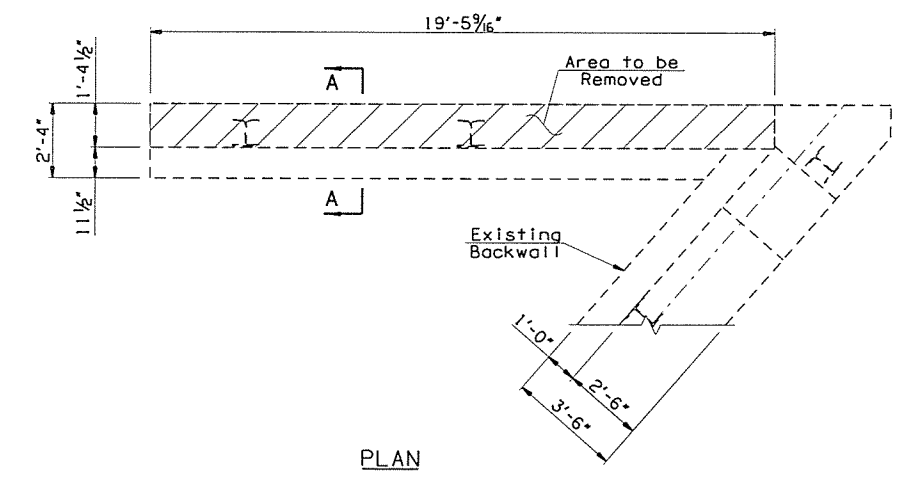
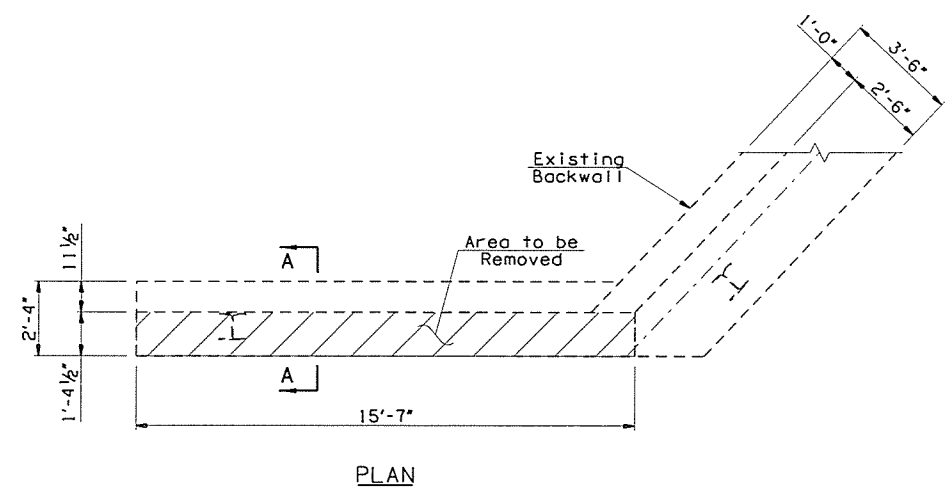

ELEVATION

SECTION A-A

ELEVATION

SECTION A-A

**SOUTHWEST WING**

**ABUTMENT NO. 1 WING DEMOLITION DETAILS**

**NORTHWEST WING**

**NOTES:**

All incidental construction required for the removal of portions of existing Wingwalls, including concrete removal, excavation, saw cutting, labor & equipment shall be included in the price per Lump Sum of "REMOVAL OF BRIDGE ITEMS".

All dimensions of the existing components shown on the plans are approximate. The contractor shall verify all data necessary to remove portions of the existing Abutments & shall be solely responsible for the accuracy thereof.

For additional demolition & construction details at Abutment No. 1, see Sheet Nos. 32 & 33.

For Abutment No. 2 demolition details, see Sheet No. 31.

For Bar Lists, Bar Bends, & Summary of Quantities, see Sheet No. 34.

**LEGEND**

- Demolition cost to be included in the price bid per Lump Sum of "REMOVAL OF BRIDGE ITEMS".
- Existing Structure

I-44 EB OVER S 38TH W AVE TULSA COUNTY		DESIGN	JMO	8/15
& TSU RR		DETAIL	SJL	9/15
BRIDGE "B"		CHECK	BRT	11/15
ABUTMENT DETAILS (SHEET 1 OF 5)		<b>GARVER</b>		

STATE OF OKLAHOMA	DEPARTMENT OF TRANSPORTATION
JOB PIECE NO. 28872(04)	SHEET NO. 30