

APPROACH SLAB NO. 1 REINFORCING PLAN

FS2 BARS PROJECTING FROM APPROACH SLAB INTO TRAFFIC RAILS HAVE BEEN OMITTED FOR CLARITY. SEE SHEET 16 FOR PLACEMENT OF FS2 BARS.

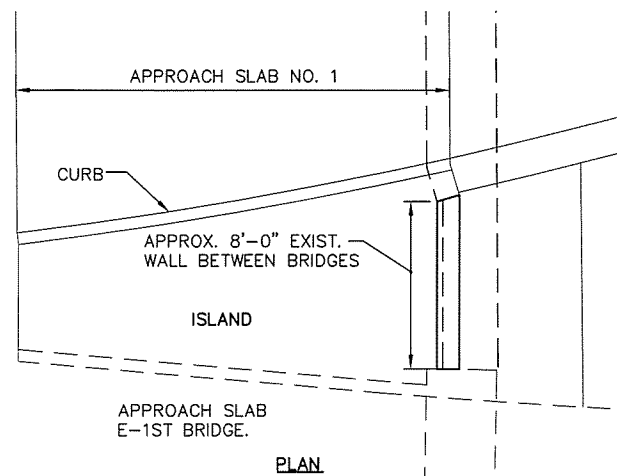

PLAN

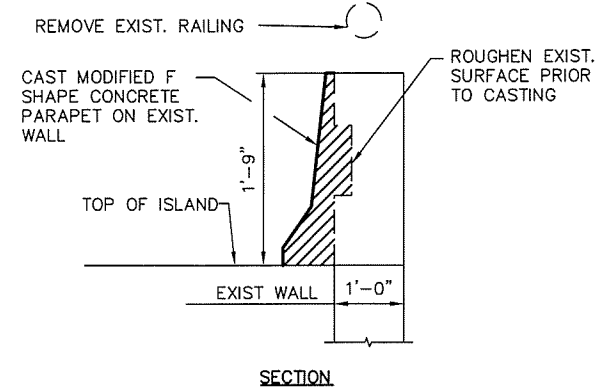

SECTION

DETAILS OF WALL FACE TREATMENT BETWEEN BRIDGES

ALL COSTS ASSOCIATED WITH THE WALL FACE TREATMENT SHALL BE INCLUDED IN OTHER BID ITEMS

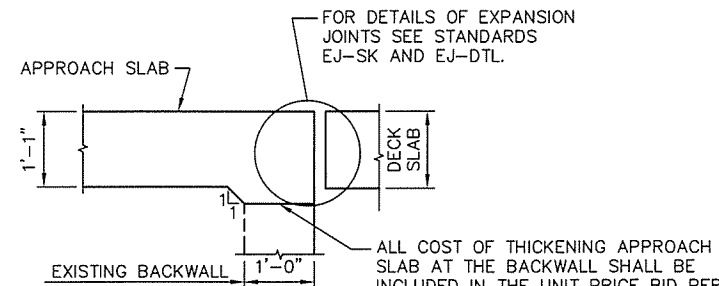

SECTION THROUGH EXPANSION JOINT BETWEEN APPROACH SLAB AND DECK SLAB

ALL COST OF THICKENING APPROACH SLAB AT THE BACKWALL SHALL BE INCLUDED IN THE UNIT PRICE BID PER SQUARE YARD OF "APPROACH SLAB"

BAR LIST-APPROACH SLAB NO. 1					
MARK	NO.	SIZE	FORM	LENGTH	LENGTH VARIATION
EPOXY COATED					
AE	2	#5	BNT.	17'-5"	
BL1	23	#9	STR.	18'-4"	
BL2	2	#9	STR.	18'-6"	
BT1	19	#4	STR.	16'-10" AVG.	16'-3" TO 17'-5"
CH1	1	#4	STR.	18'-4"	
CT	38	#4	BNT.	2'-0"	
FS2	16	#5	BNT.	7'-4"	
TL1	16	#4	STR.	18'-4"	
TL2	2	#4	STR.	18'-6"	
TT1	19	#4	STR.	16'-10" AVG.	16'-3" TO 17'-5"

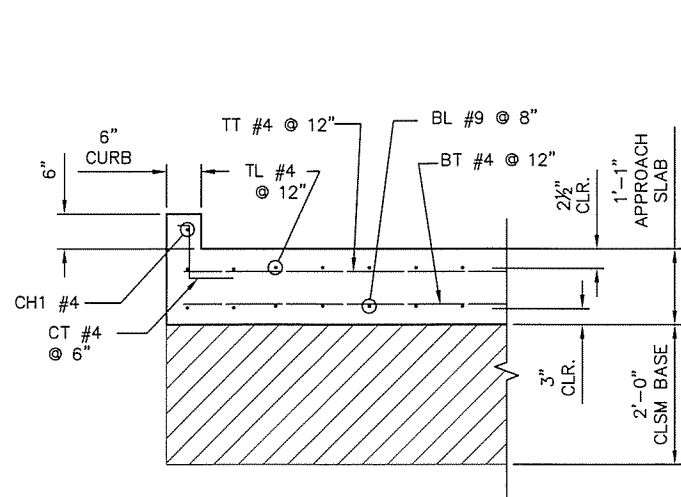

CURB SECTION

TYPICAL APPROACH SLAB SECTION

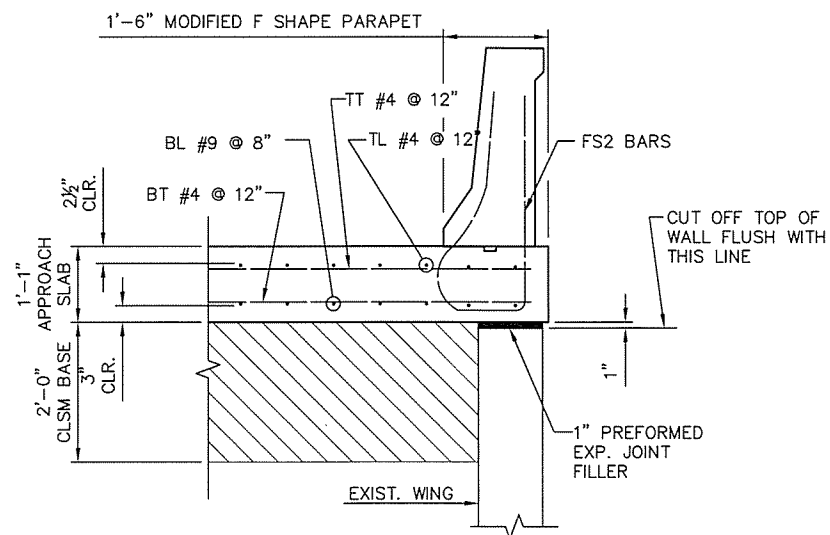

SECTION AT WING

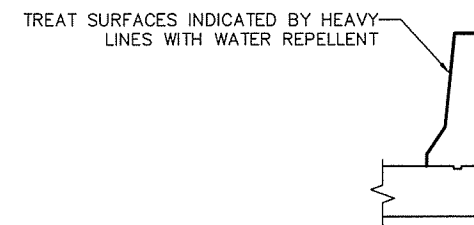

WATER REPELLENT TREATMENT DETAIL

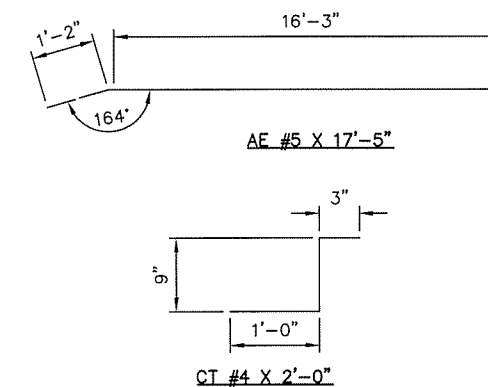

DETAILS OF BENT REINFORCEMENT

DESIGN	SJN	01/09	N-1ST RAMP OVER US75 APPROACH SLABS DETAILS (SHEET NO. 1 OF 2)	TULSA COUNTY
DRAWN	SJN	01/09		
CHECKED	SAL	01/09		
APPROVED				
SQUAD	BKQ			
STATE JOB PIECE NO. 28879(04)			SHEET NO. 17	

X:\Projects\611-ODOT-IDL North & South Bound Lanes\DWG\Sheets\611-BRIDGE 15\SHEETS\517-SB-BR15-AS01.dwg, 5/13/2016 8:34:47 AM, cdm