

REVISIONS		
REV. NO.	DESCRIPTION	DATE

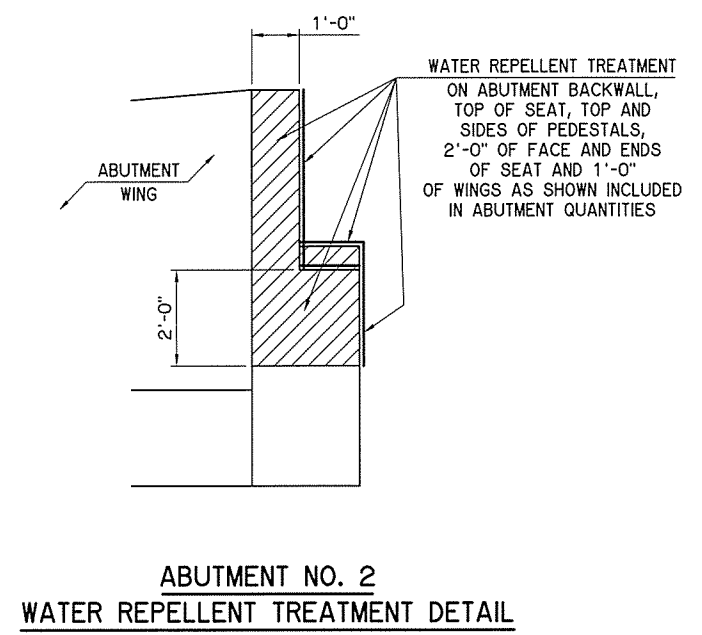
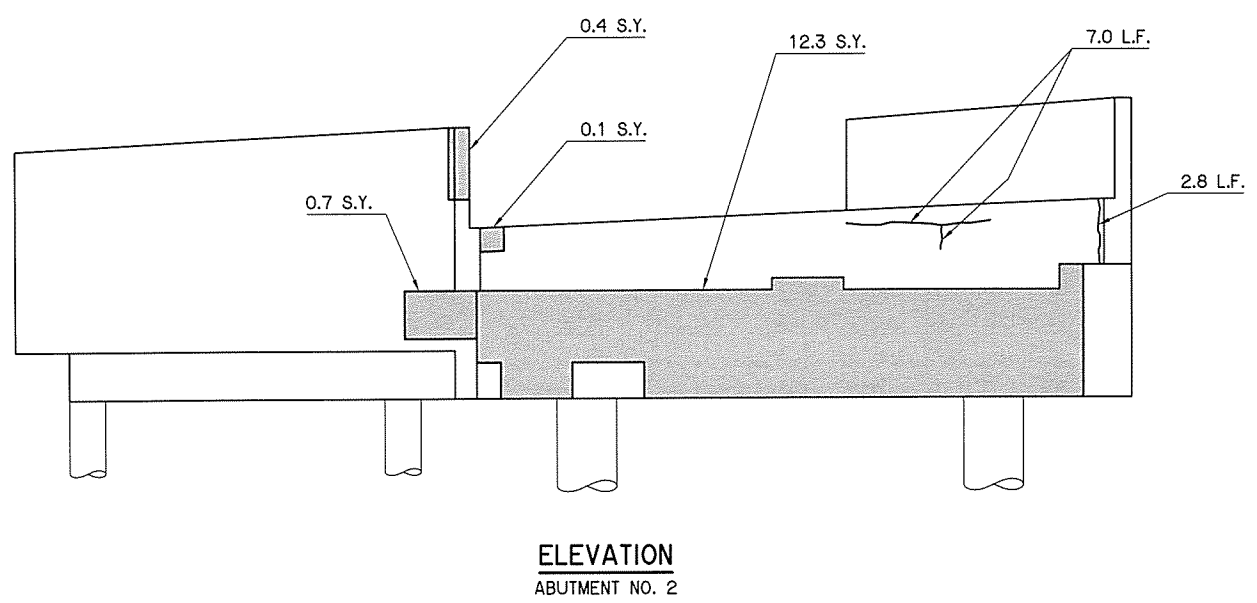
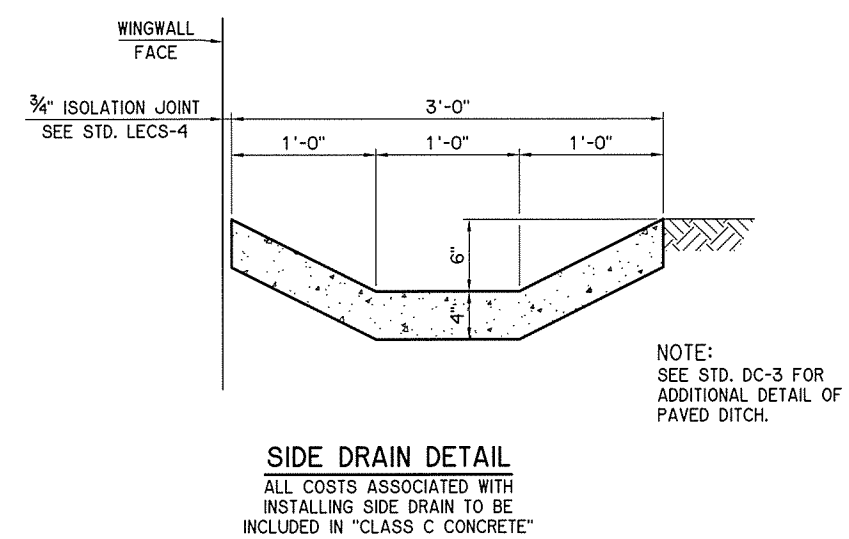
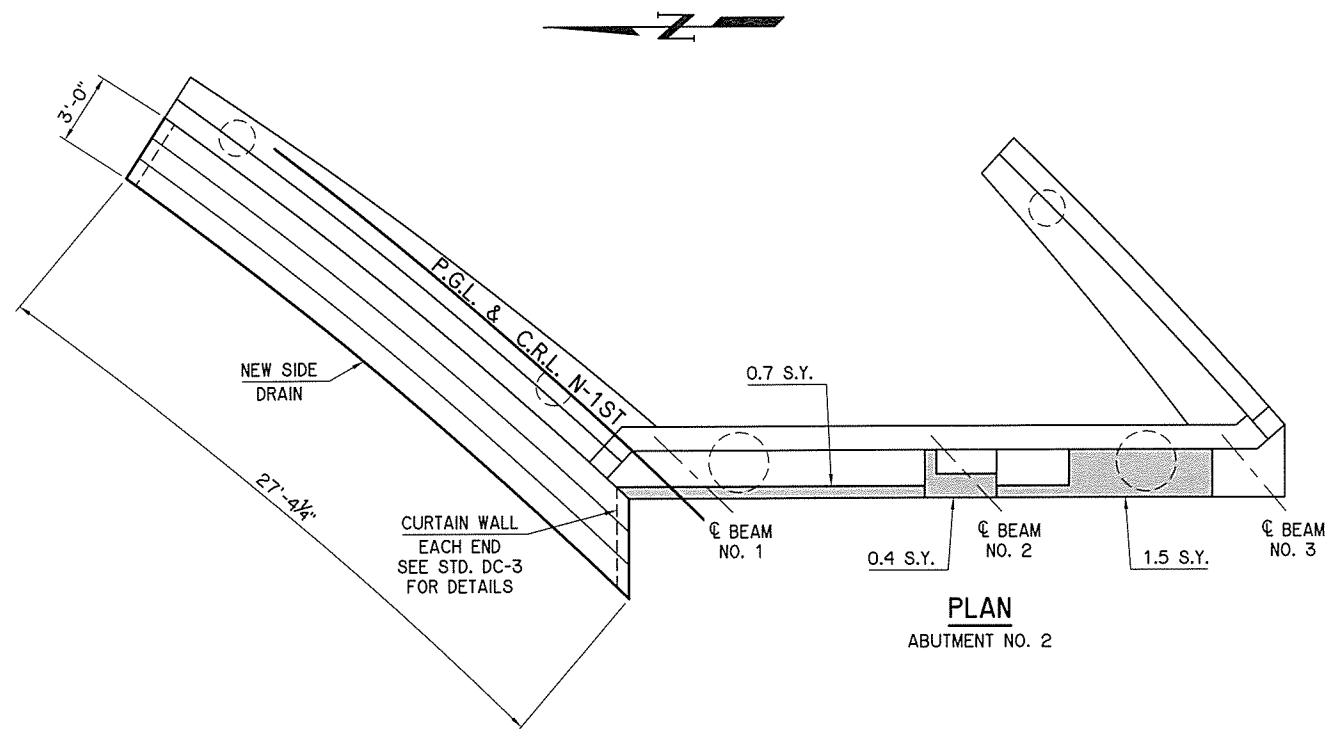

NOTE:  
FOR PNEUMATIC MORTAR REPAIR  
SEE SHEET 5.

- LEGEND**
- PNEUMATICALLY PLACED MORTAR WITH CORROSION INHIBITOR (SURFACE APPLIED)
  - PREPARATION OF CRACKS, ABOVE WATER

N-1ST RAMP OVER U.S. 75		TULSA COUNTY		Design	JNS
<b>ABUTMENT REPAIR DETAILS</b> SHEET 2 OF 2 ABUTMENT NO. 2				Detail	HEJ
				Check	JNS
<b>STATE OF OKLAHOMA</b>				WHITE ENGINEERING ASSOCIATES	
				DEPARTMENT OF TRANSPORTATION	

I:\Active\1445\Drawings\Structural\6 Abutment Repair Dtls Sheet 2 of 2.dwg, 5/12/2016 10:09:01 AM, Howard