

DESCRIPTION	REVISIONS	DATE

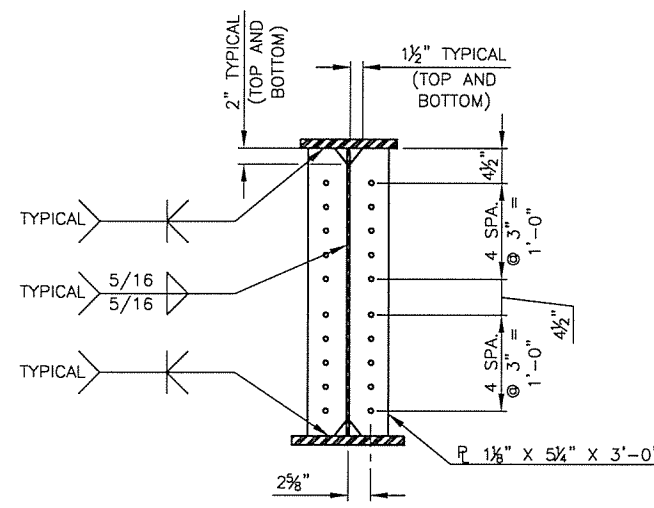

BEARING STIFFENER DETAILS

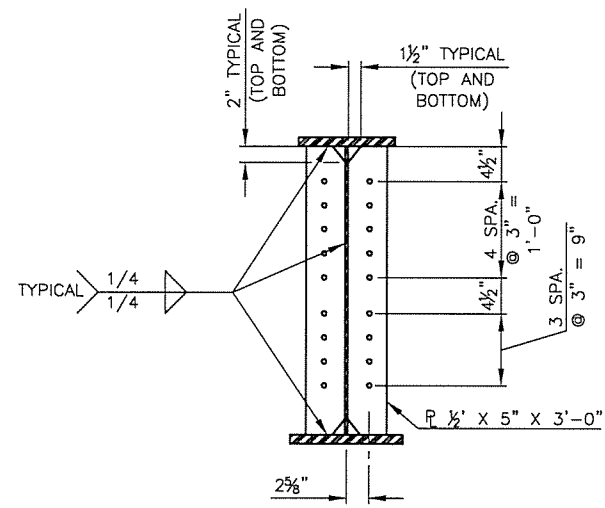

INTERMEDIATE DIAPHRAGM STIFFENER DETAILS

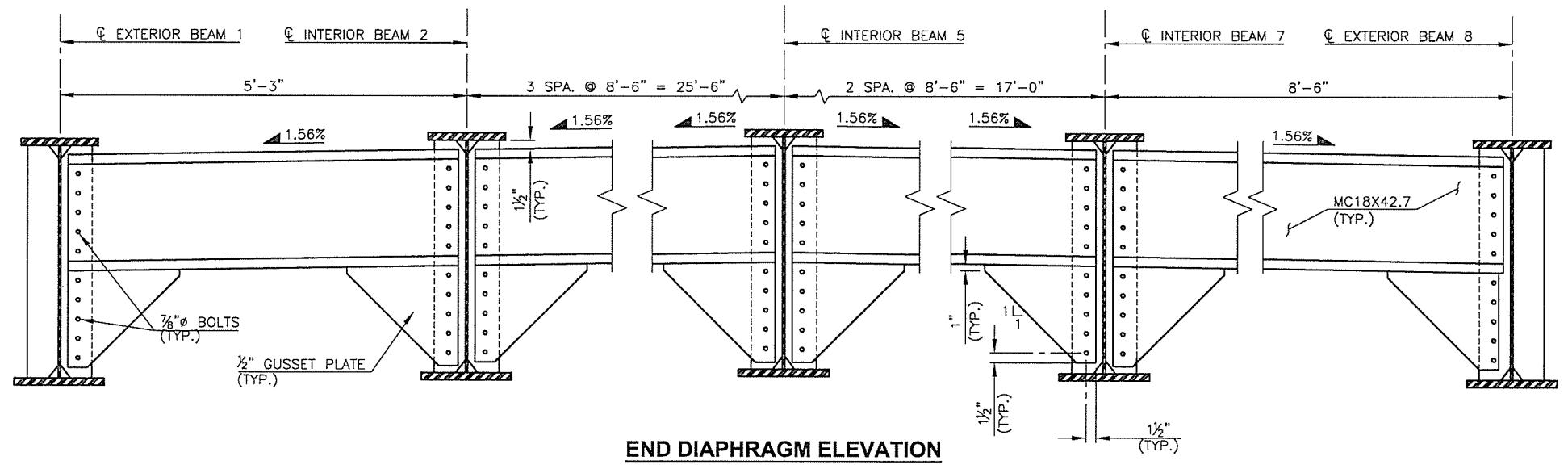

END DIAPHRAGM ELEVATION

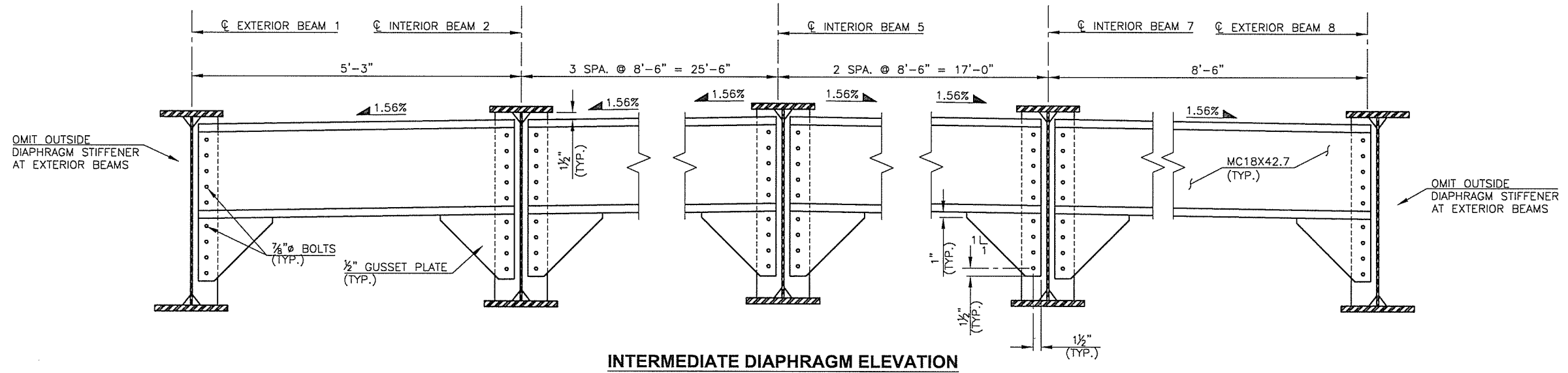

INTERMEDIATE DIAPHRAGM ELEVATION

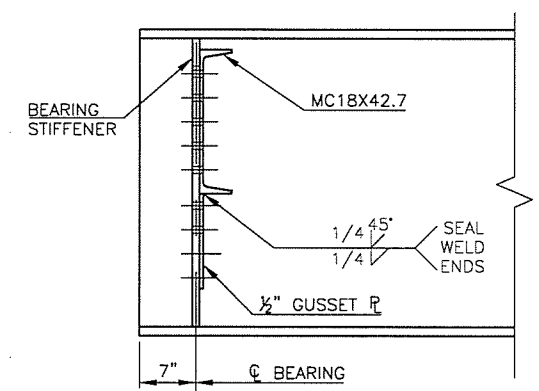

END DIAPHRAGM SECTION

NOTE:
OMIT BOLT HOLES AT OUTSIDE STIFFENERS OF EXTERIOR BEAMS.

NOTE:
TERMINATE FILLET WELDS 3/8" FROM THE EDGE OF CLIPPED CORNERS OF ALL STIFFENER PLATES AND NON-CLIPPED CORNERS OF INTERMEDIATE DIAPHRAGM STIFFENERS. WRAP FILLET WELD AROUND NON-CLIPPED CORNERS OF BEARING STIFFENERS.

DESIGN	B.J.K.	4TH OVER 1-444	TULSA COUNTY
DRAWN	R.A.P. J.F.R.		
CHECKED	B.J.K. J.W.H.		
APPROV.	T.A.C.		
SQUAD	CEC	JOB PIECE NO. 28868(04)	SHEET NO. 19

DIAPHRAGM DETAILS