

DESCRIPTION	REVISIONS	DATE

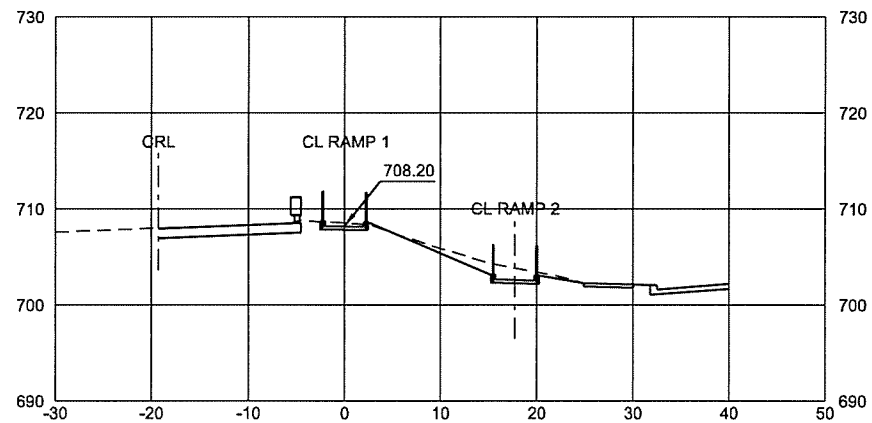

WP1+10

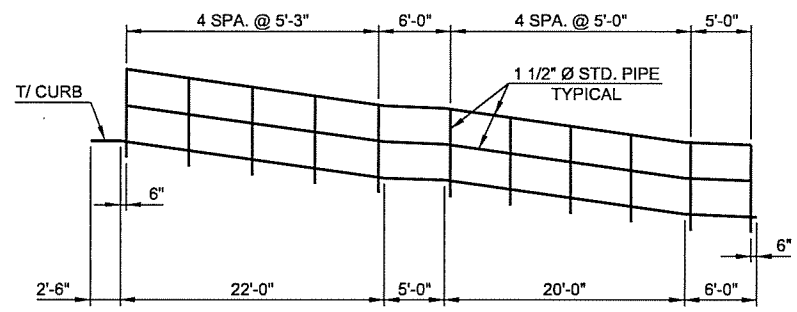

NORTH RAIL HC RAMP 1

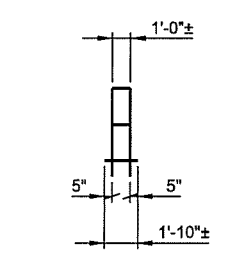

WEST RAIL TRANSITION LANDING

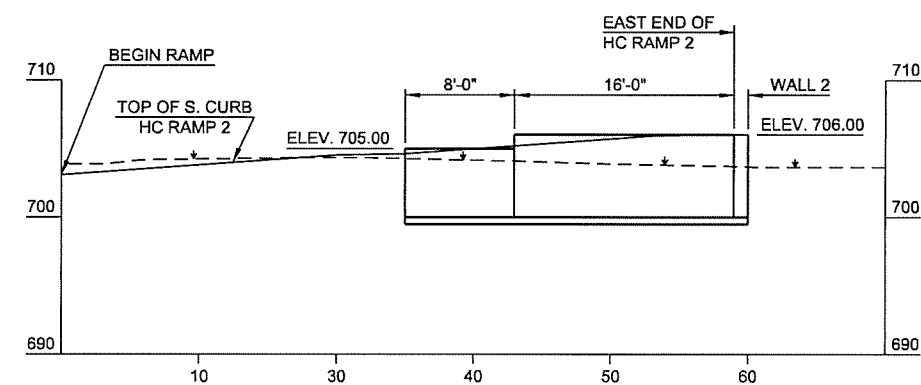

ELEVATION RETAINING WALL #1

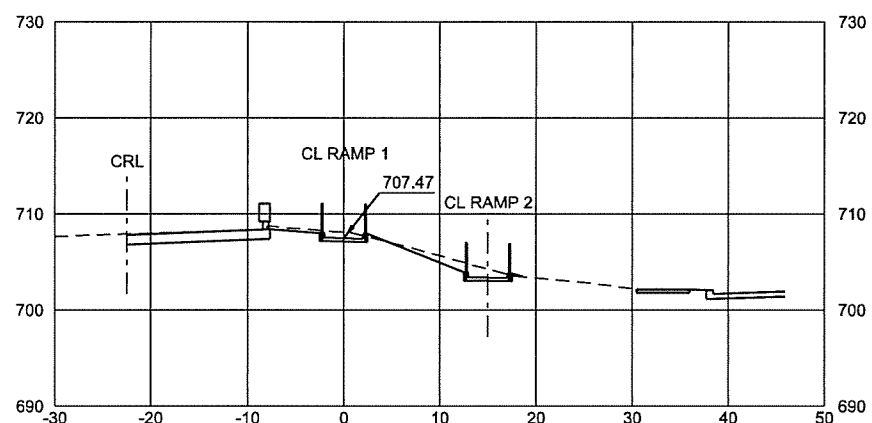

WP1+20

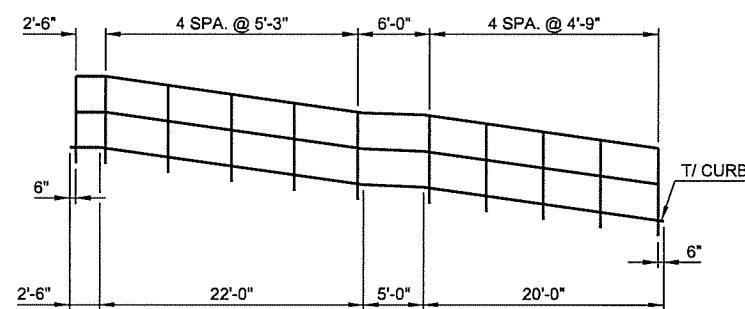

SOUTH RAIL HC RAMP 1

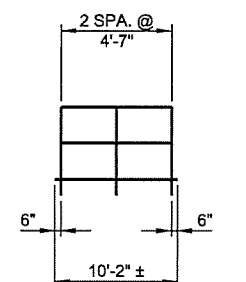

EAST RAIL TRANSITION LANDING

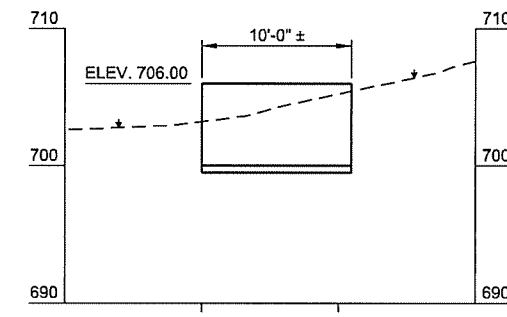

ELEVATION RETAINING WALL #2

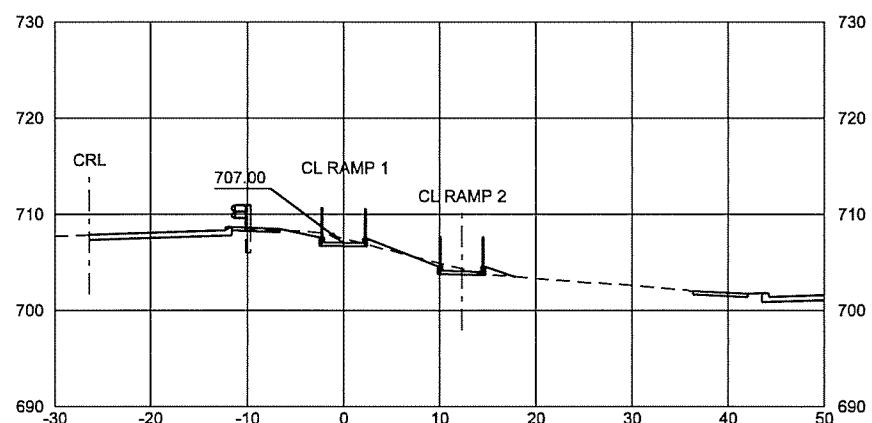

WP1+30

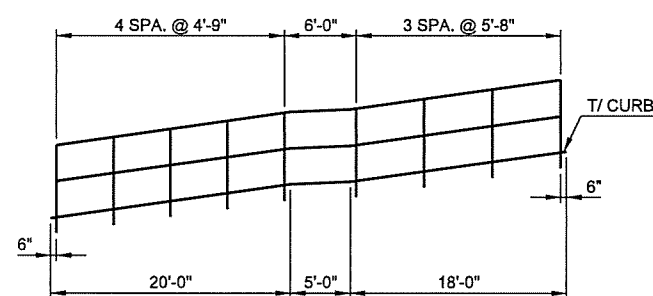

NORTH RAIL HC RAMP 2

NOTE:
TOP OF RAIL SHALL HAVE SAME
SLOPE AS TOP OF CURB. SEE
RAMP PROFILES.

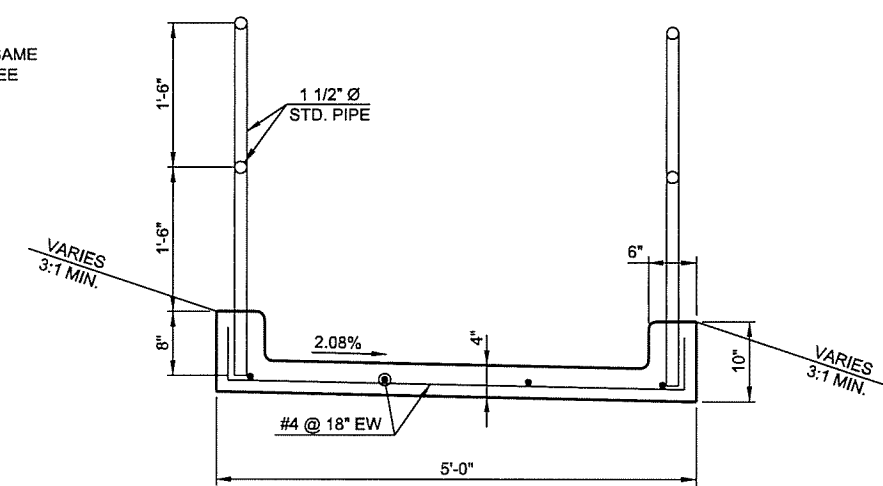

TYPICAL SECTION

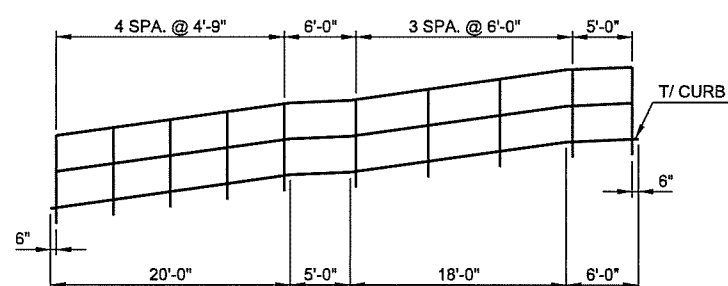

SOUTH RAIL HC RAMP 2

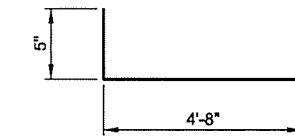

BAR BEND

DESIGN	JWB	3-16	OKLAHOMA DEPARTMENT OF TRANSPORTATION
DRAWN	MRM	3-16	
CHECKED	JSH	3-16	
APPROVED			
SQUAD	TT		
			STAIRS AND HANDICAP RAMP
			SHEET 2 OF 2
			STATE JOB NO. 28865(04) SHEET NO. 76
			TULSA CO. 2ND STREET

6/7/2016 N:\11399\200-11399-13001-05\CAD\SheetFiles\JP 28865 (04) -76-RD -Wheel Chair.2.dgn