

TYPICAL SECTION NO. 1
2ND STREET
 STA. 226+23.68 TO 226+73, 2ND STREET CRL

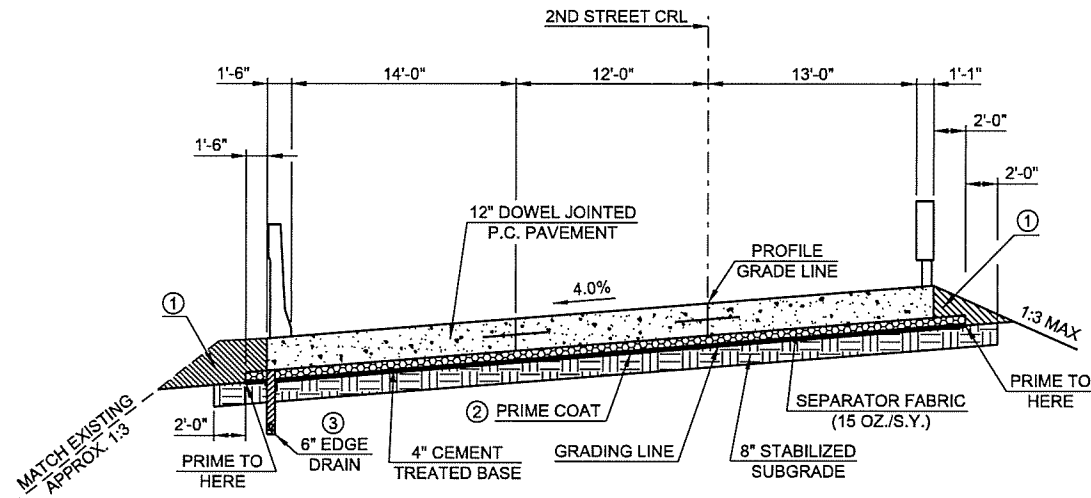

TYPICAL SECTION NO. 3
2ND STREET
 STA. 226+86 TO 227+00, 2ND STREET CRL

- ① TO BE BACKFILLED AND COMPACTED AS PART OF THE FINISHING OPERATIONS. COST TO BE INCLUDED IN UNCLASSIFIED BORROW.
- ② PRIME COAT TO BE APPLIED TO FULL WIDTH OF TOP OF SUBGRADE (0.35 GAL/S.Y.)
- ③ SEE ODOT STD. DRAWING PED-3-2 FOR PAVEMENT EDGE DRAIN DETAILS.

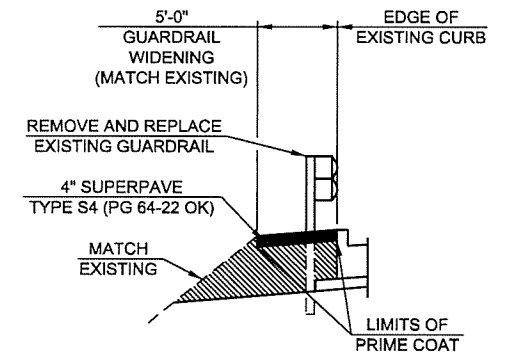

GUARDRAIL WIDENING
2ND STREET

STA. 227+00 RT. TO 228+43.15 RT., 2ND STREET CRL

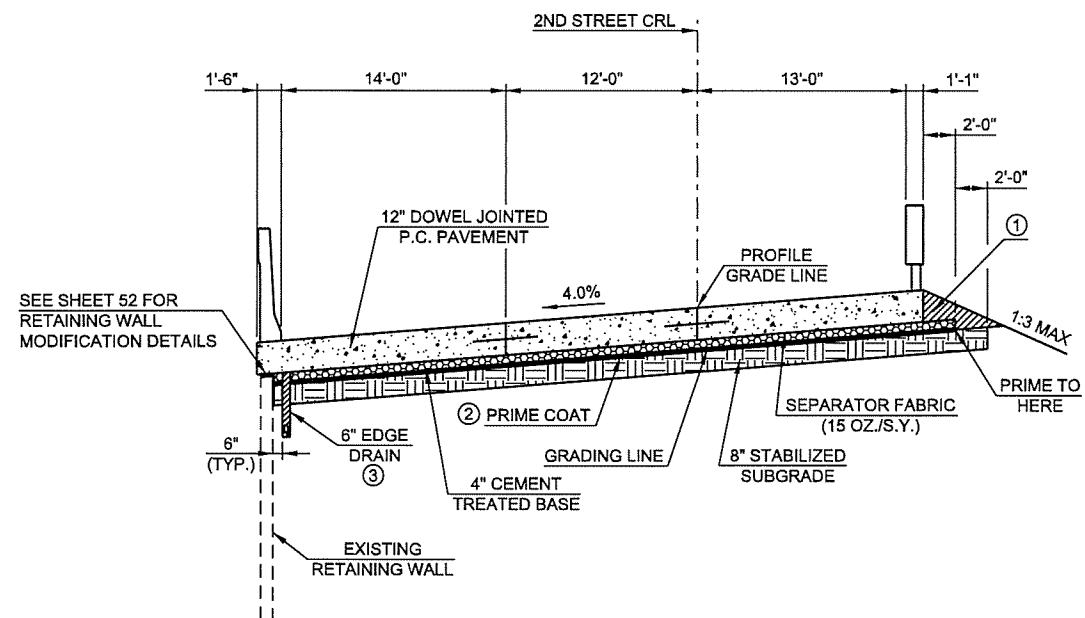

TYPICAL SECTION NO. 2
2ND STREET
 STA. 226+73 TO 226+86, 2ND STREET CRL

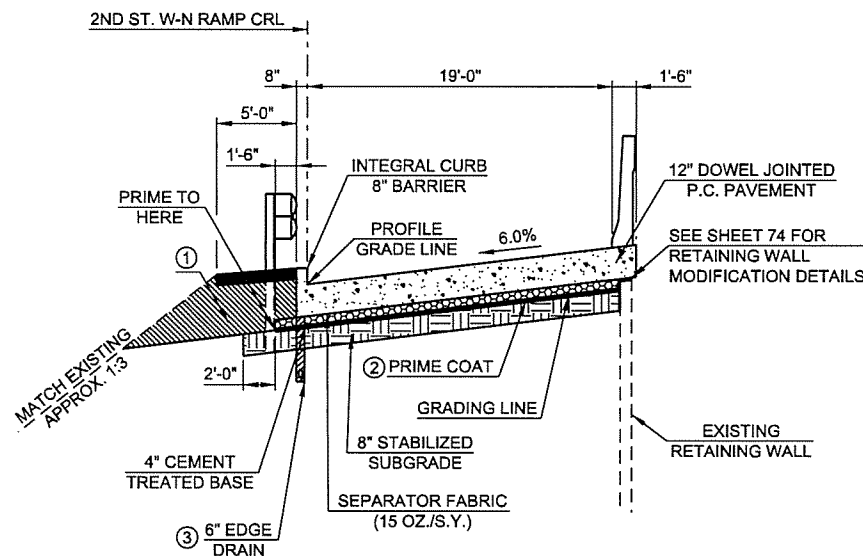

TYPICAL SECTION NO. 4
2ND STREET RAMP

STA. 520+70.12 TO 521+20, 2ND ST. W-N RAMP CRL

2ND STREET RAMP
 STA. 520+70.12 LT. TO 521+63.27 LT., 2ND ST. W-N RAMP CRL
 STA. 521+20 RT. TO 521+63.27 RT., 2ND ST. W-N RAMP CRL

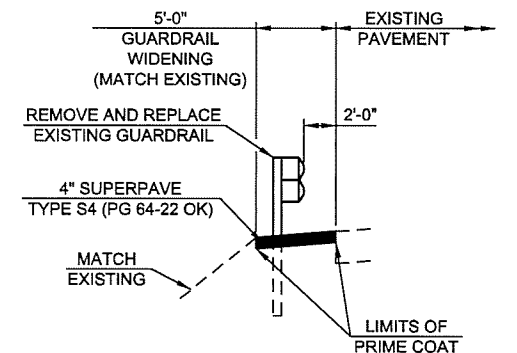

GUARDRAIL WIDENING
2ND STREET

STA. 227+00 LT. TO 229+18.15 LT., 2ND STREET CRL

N:\11399\200-11399-13001-05\CAD\SheetFiles\JP 28865 (04) -03-RD-Typical.Sec.dgn 6/6/2016

DESIGN			DRAWN			CHECKED			APPROVED			SQUAD		
JSH	1-1-6		MRM	1-1-6		LWN	3-1-6							
2ND STREET AND RAMP OVER I-444														
OKLAHOMA DEPARTMENT OF TRANSPORTATION														
TYPICAL SECTIONS														
STATE JOB NO. 28865(04) SHEET NO. 3														
TULSA CO. 2ND STREET														