

I-244 TURNING ROADWAY TYPICAL SECTION NO. 1
WESTBOUND (TWO LANE - ONE WAY RAMP)
 NOT TO SCALE
 RAMP A
 RAMP STA. 752+97.12 TO STA. 761+04.47

▲ RAMP STA. 760+54.97 TO STA. 761+04.47 - TRANSITION 10'-0" TO 10'-8 1/2"

PAVT. STRUCTURE	DRIVING LANES AND INSIDE SHOULDER	OUTSIDE SHOULDER
SURFACE COURSE	11" DOWEL JOINTED P.C. CONCRETE	11" TIED PLAIN JOINTED P.C. CONCRETE
INTERMEDIATE COURSE	4" OPEN GRADED BITUMINIOUS BASE	4" OPEN GRADED BITUMINIOUS BASE
BASE COURSE	8" AGGREGATE BASE TYPE 'A'	8" AGGREGATE BASE TYPE 'A'
SUBGRADE	8" STABILIZED SUBGRADE	8" STABILIZED SUBGRADE

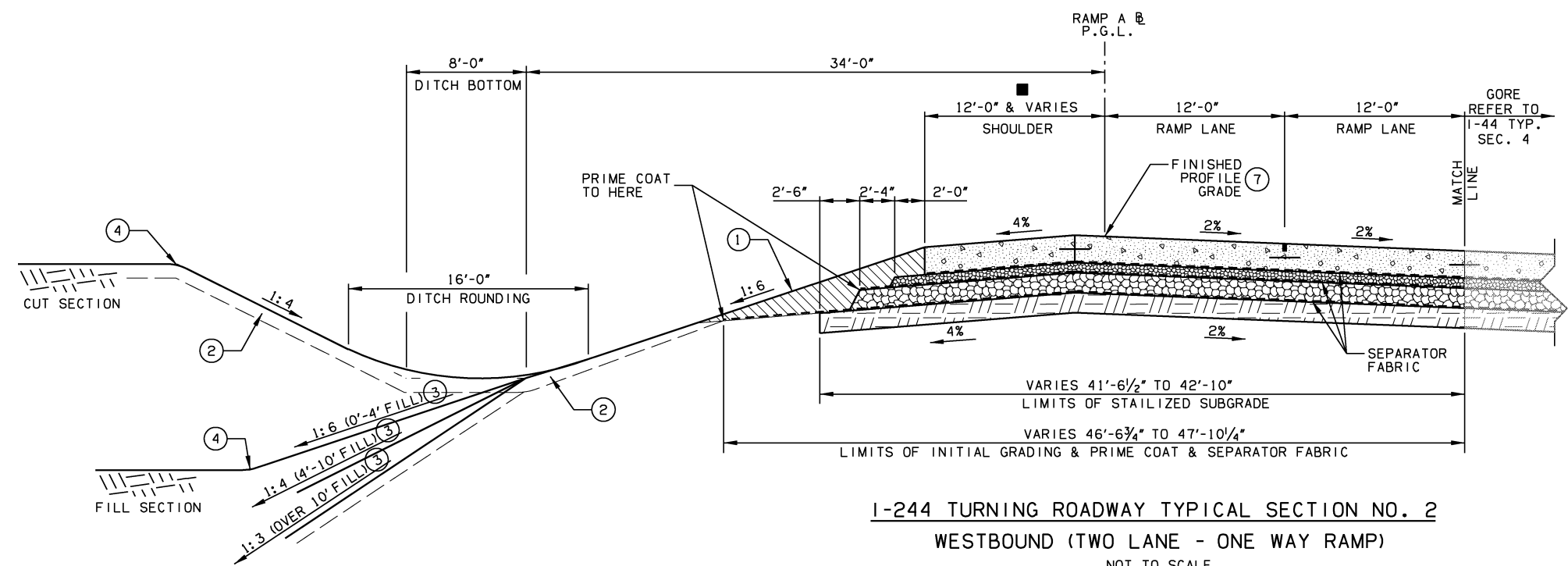

I-244 TURNING ROADWAY TYPICAL SECTION NO. 2
WESTBOUND (TWO LANE - ONE WAY RAMP)
 NOT TO SCALE
 RAMP A
 RAMP STA. 761+04.47 TO STA. 766+99.69

■ RAMP STA. 761+10.02 TO STA. 762+00.52 - TRANSITION 10'-8 1/2" TO 12'-0"

PAVT. STRUCTURE	DRIVING LANES	SHOULDERS
SURFACE COURSE	11" DOWEL JOINTED P.C. CONCRETE	11" TIED PLAIN JOINTED P.C. CONCRETE
INTERMEDIATE COURSE	4" OPEN GRADED BITUMINIOUS BASE	4" OPEN GRADED BITUMINIOUS BASE
BASE COURSE	8" AGGREGATE BASE TYPE 'A'	8" AGGREGATE BASE TYPE 'A'
SUBGRADE	8" STABILIZED SUBGRADE	8" STABILIZED SUBGRADE

- ① BACKFILL NOTE:
THIS AREA IS TO BE BACKFILLED AND COMPACTED AS PART OF FINISHING OPERATIONS. BACKFILL MATERIAL TO BE TBSO TYPE "E", AND PAID AS SUCH. MEASUREMENT BASED ON THEORETICAL CROSS SECTION.
- ② TOPSOIL NOTE:
THE CONTRACTOR SHALL STRIP ALL OF THE AVAILABLE TOPSOIL, STOCKPILE IT, AND REPLACE IT IN ACCORDANCE WITH SECTION 205 OF THE STANDARD SPECIFICATIONS. RESERVED TOPSOIL SHALL BE SPREAD APPROX. 5" THICK FIRST ON THE COMPLETED SLOPES OF THE CUT SECTION, AND THE REMAINDER ON COMPLETED FILL SLOPES OR OTHER PRIORITY AREAS LOCATED BY THE ENGINEER. THE GRADING LINE AS SHOWN ON THE TYPICAL AND CROSS SECTIONS IS TO THE TOP OF TOPSOIL. EARTHWORK QUANTITIES WERE NOT ADJUSTED FOR SALVAGED TOPSOIL AND THE TOPSOIL QUANTITY IS INCLUDED IN THE MASS LINE BALANCE AND EARTHWORK SUMMARY.
- ③ DISTANCE MEASURED VERTICALLY FROM EDGE OF FINISHED SHOULDER.
- ④ SEE ROUNDING DETAIL SHEET 6.
- ⑦ REVOLVE THE SUPERELEVATION ABOUT THE PROFILE GRADE POINT.

DESIGN	DLT	8/12	TULSA & ROGERS COUNTIES
DRAWN	TML	8/12	
CHECKED	KMM	6/16	
APPROVED			
SQUAD	GARVER		

TYPICAL SECTIONS
(SHEET 5 OF 8)

STATE JOB NO. 21899(04) SHEET NO. 7