

PAVEMENT REQUIREMENT	
8" PAVT. STRUCTURE	13'-0" DRIVING LANES
SURFACE COURSE	2" SUPERPAVE TYPE S4 (PG 64-22 OK)
BASE COURSE	3" SUPERPAVE TYPE S3 (PG 64-22 OK)

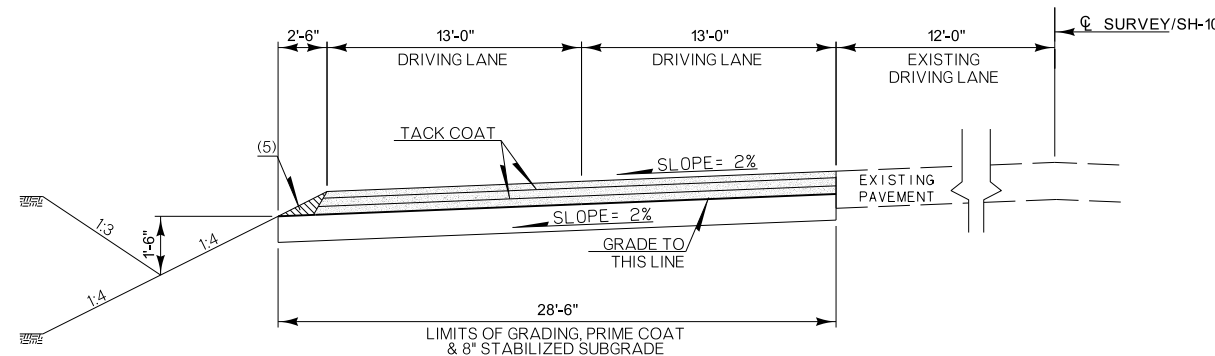

PAVEMENT REQUIREMENT	
7" PAVT. STRUCTURE	13'-0" DRIVING LANES
SURFACE COURSE	2" SUPERPAVE TYPE S4 (PG 64-22 OK)
BASE COURSE	2.5" SUPERPAVE TYPE S3 (PG 64-22 OK)

- (1) BACKFILL NOTE:
TO BE BACKFILLED AS PART OF THE FINISHING OPERATIONS.
COST TO BE INCLUDED IN T.B.S.C. TYPE E.
- (2) TOPSOIL NOTE:
THE CONTRACTOR SHALL STRIP ALL OF THE AVAILABLE TOPSOIL, STOCKPILE IT, AND PLACE IT BACK ON THE SECTION IN ACCORDANCE WITH SECTION 205 OF THE STANDARD SPECIFICATIONS. RESERVED TOPSOIL SHALL BE SPREAD FIRST ON THE COMPLETED SLOPES OF THE CUT SECTIONS AND THE REMAINDER ON COMPLETED FILL SLOPES OR OTHER PRIORITY AREAS LOCATED BY THE ENGINEER. ALL ADDITIONAL COSTS ASSOCIATED WITH OPERATIONS SHALL BE INCLUDED IN THE PAY ITEM FOR SALVAGED TOPSOIL, LUMP SUM.

THE GRADING LINE AS SHOWN ON THE TYPICAL AND CROSS SECTIONS IS TO THE TOP OF THE TOPSOIL. EARTHWORK QUANTITIES WERE NOT ADJUSTED FOR SALVAGE AND THE TOPSOIL QUANTITY IS INCLUDED IN THE MASS LINE BALANCE.
- (3) DISTANCE MEASURED VERTICALLY FROM EDGE OF FINISHED GRADE SHOULDER.
- (4) PRIME COAT ON TOP OF AGGREGATE BASE.
- (5) BACKFILL NOTE:
TO BE BACKFILLED AND COMPACTED AS PART OF THE FINISHING OPERATIONS.
COST TO BE INCLUDED IN UNCLASSIFIED BORROW.

ROUNDING DETAIL

● INTERSECTION OF CUT AND/OR FILL SLOPES WITH GROUND LINE TO BE ROUNDED AS PART OF FINISHING OPERATIONS. ROUNDED SHALL BE 5' MINIMUM FOR SMALLER CUTS AND FILLS TO 15' MAXIMUM FOR LARGER CUTS AND FILLS OR AS DESIGNATED BY THE ENGINEER. COST OF ROUNDED TO BE INCLUDED IN PRICE BID FOR OTHER ITEMS OF WORK.

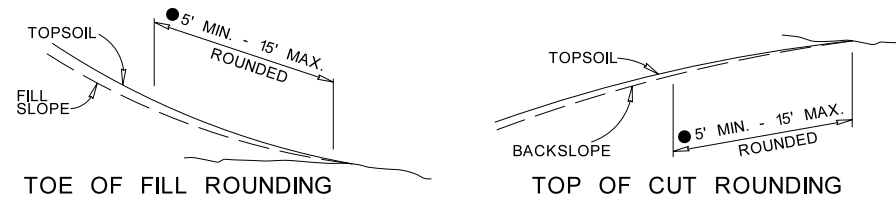

DESIGN		OKLAHOMA DEPARTMENT OF TRANSPORTATION ROADWAY DESIGN DIVISION
DRAWN		
CHECKED		
APPROVED		
SQUAD		

TYPICAL SECTION

STATE JOB NO. 27956(04) SHEET NO. 7
MUSKOGEE CO. US-62/SH-10