

BAR BENDING DIAGRAMS
(ALL DIMENSIONS ARE OUT TO OUT)

OUTLET HEADWALL BAR LIST						
MARK	NO.	SIZE	FORM	LENGTH	LENGTH VARIATION	
PLAIN REINFORCING						
AC1	4	#4	BNT.	4'-8"		
AD1	4	#6	STR.	69'-8"		
AL1	88	#4	STR.	58'-8"		
AL2	128	#4	STR.	30'-3 1/2" (AVG.)	3'-5" TO 57'-2"	
AL3	88	#4	STR.	5'-0"		
AT1	4	#6	STR.	111'-1"		
AT2	168	#5	STR.	86'-6" (AVG.)	62'-8" TO 110'-4"	
AT3	66	#5	STR.	50'-5" (AVG.)	41'-3" TO 59'-7"	
CH	6	#6	STR.	41'-2"		
CL1	42	#5	BNT.	5'-8"		
CL2	42	#5	BNT.	4'-3"		
CT1	16	#4	STR.	110'-1"		
CS1	213	#6	BNT.	11'-1"		
CS2	213	#6	BNT.	10'-6"		
CS3	8	#5	BNT.	10'-8"		

- ① 4 SETS OF 32 BARS
- ② 2 SETS OF 84 BARS
- ③ 2 SETS OF 33 BARS
- ④ INCLUDES 2'-0" FOR (1) LAP SPLICE
- ⑤ INCLUDES 2'-6" FOR (1) LAP SPLICE
- ⑥ INCLUDES 3'-0" FOR (1) LAP SPLICE

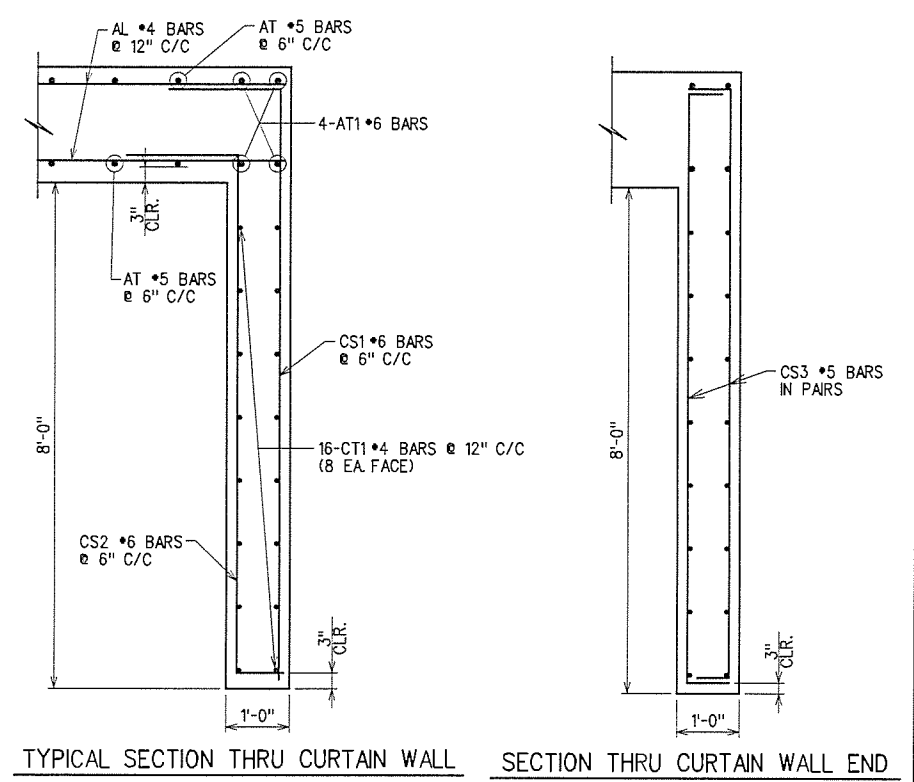
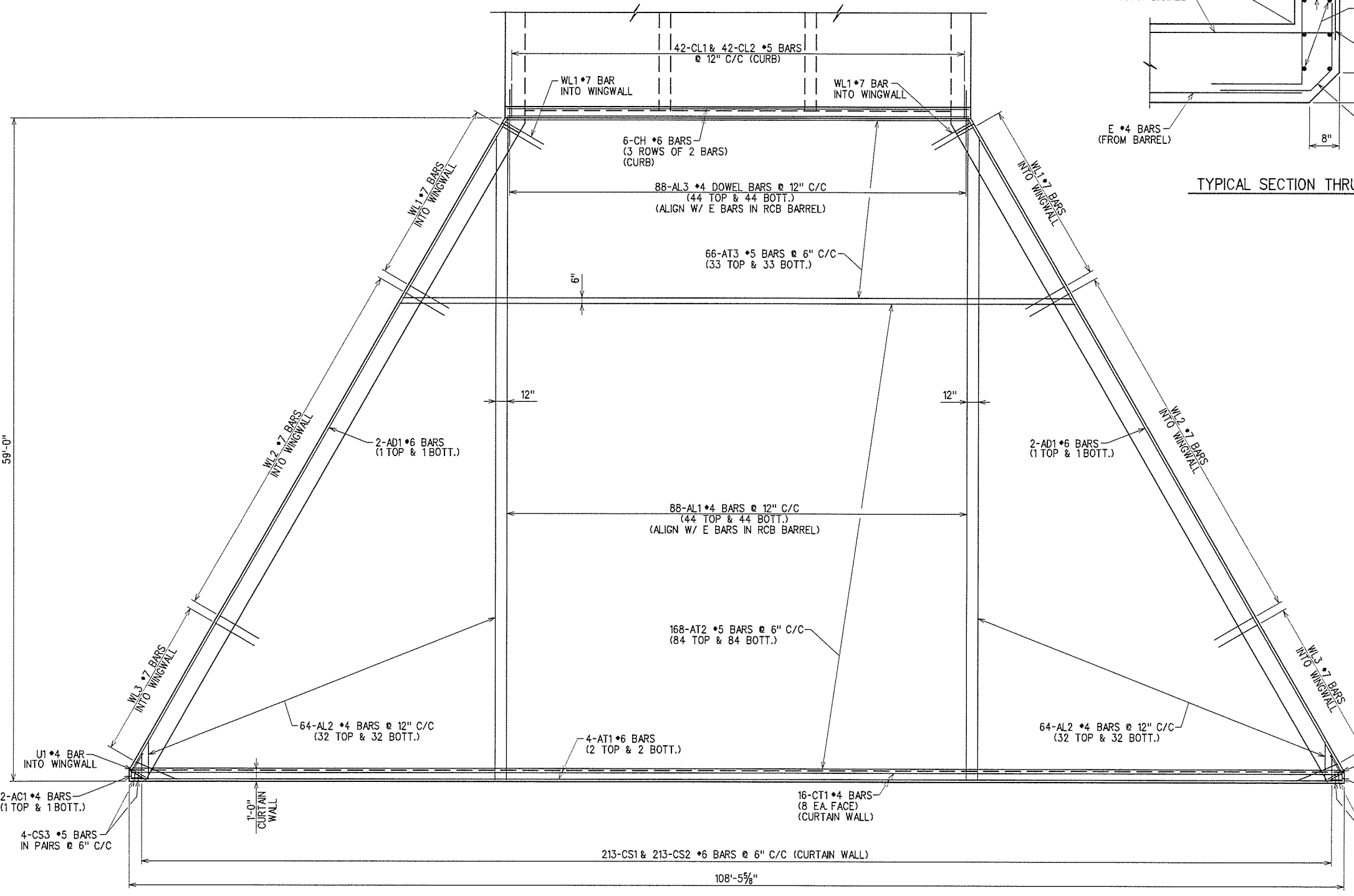
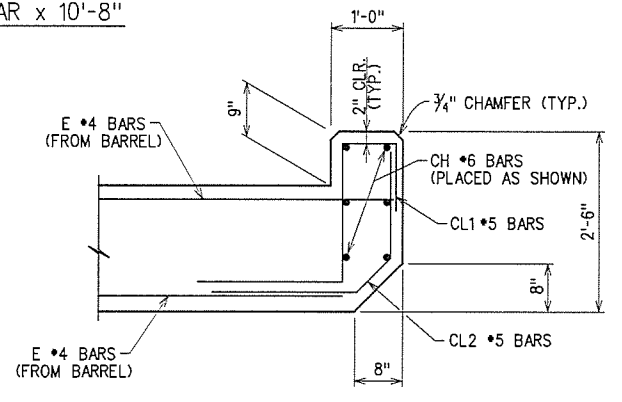

X:\Odot\EC-1394F-2\Struc\Bridge_A\Headwall.dgn

12/8/2015