

BRICK STAMPED FACE PATTERN

RED DYED CONCRETE WITH
BRICK STAMPED FACE
(SEE SPECIAL PROVISION)

- (1) BACKFILL NOTE:
THIS AREA TO BE BACKFILLED AND COMPACTED AS A PART OF THE FINISHING OPERATIONS. COST TO BE INCLUDED IN UNCLASSIFIED BORROW.
- (2) TOPSOIL NOTE:
THE CONTRACTOR SHALL STRIP ALL OF THE AVAILABLE TOPSOIL, STOCKPILE IT, AND PLACE IT BACK ON THE SECTION IN ACCORDANCE WITH SECTION 205 OF THE STANDARD SPECIFICATION. RESERVED TOPSOIL SHALL BE SPREAD FIRST ON THE COMPLETED SLOPES OF THE CUT SECTIONS AND THE REMAINDER ON COMPLETED FILL SLOPES OR OTHER PRIORITY AREAS LOCATED BY THE ENGINEER. ALL ADDITIONAL COSTS ASSOCIATED WITH OPERATION SHALL BE INCLUDED IN THE PAY ITEM FOR SALVAGED TOPSOIL, LUMP SUM. THE GRADING LINE IS TO THE TOP OF THE TOPSOIL. EARTHWORK QUANTITIES WERE NOT ADJUSTED FOR SALVAGE AND THE TOPSOIL QUANTITY IS INCLUDED IN THE MASSLINE BALANCE.
- (3) SEE ROUNDING DETAIL THIS SHEET.

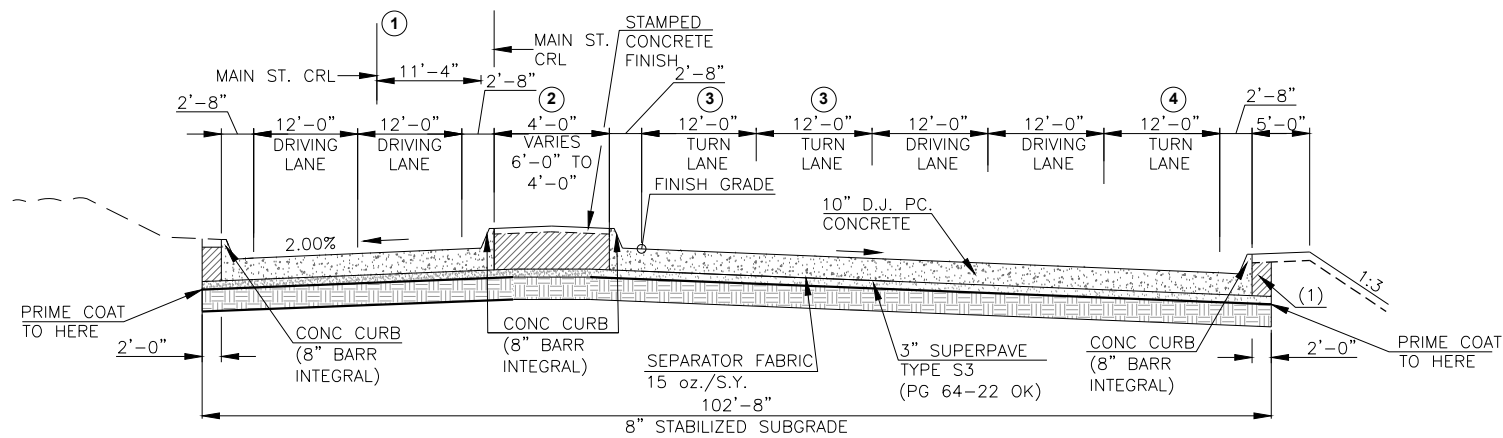

**MAIN STREET
STA. 4375+48.00 TO STA. 4379+33.58**

- ① VARIES FROM 11'-4" TO 0'-0" STA. 4380+28.74 TO STA. 4382+09.60
- ② VARIES FROM 6'-0" TO 4'-0" STA. 4375+48.00 TO STA. 4377+00.00
- ③ VARIES FROM 0'-0" TO 12'-0" STA. 4376+00.00 TO STA. 4377+00.00
- ④ VARIES FROM 0'-0" TO 12'-0" STA. 4376+00.00 TO STA. 4377+93.34

MAIN ST. CUSTER COUNTY

TYPICAL SECTION 1 OF 5

JOB PIECE NO. 27911(06) SHEET NO. 3