

NOTE: PILE ENCASEMENTS NOT SHOWN FOR CLARITY.

ABUTMENT REINFORCING PLAN

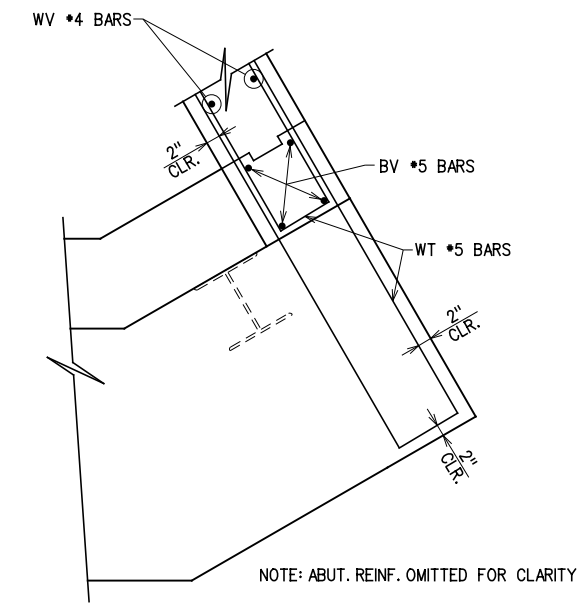

NOTE: ABUT. REINF. OMITTED FOR CLARITY

WING REINFORCING DETAIL

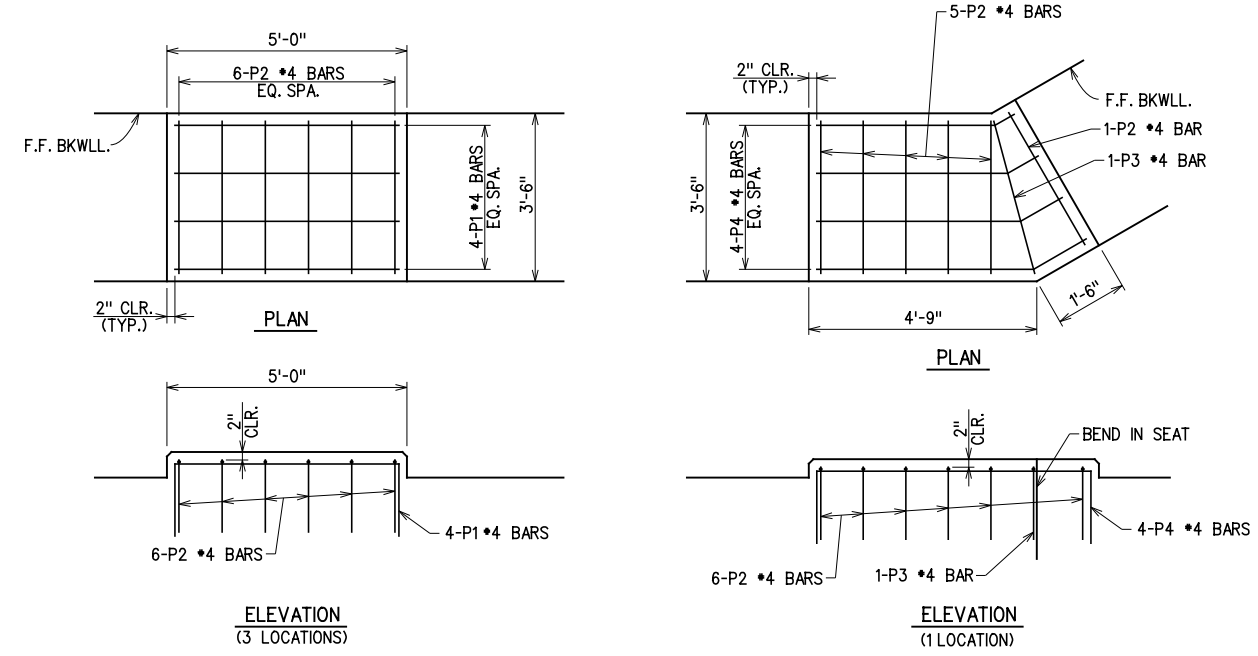

PEDESTAL DETAILS

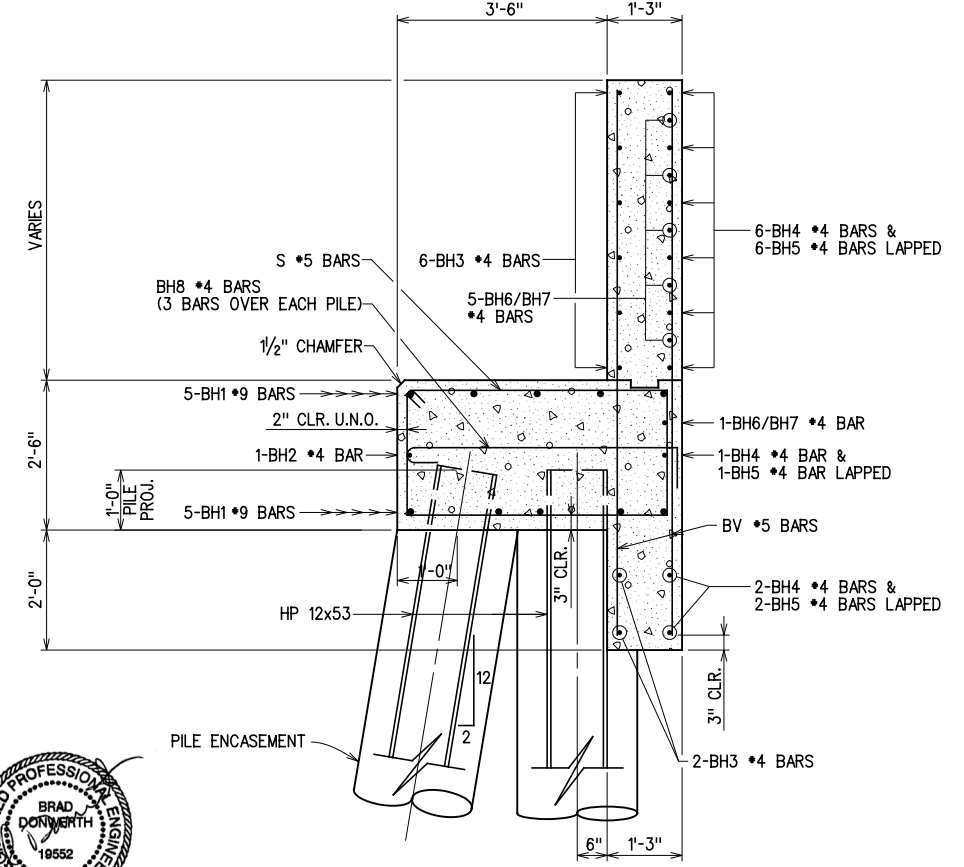

SECTION A-A



X:\guernsey\EC-1360\Struc\Bridge_C\ABUT1-2.dgn 6/2/2016

GROSSMAN & KEITH ENGINEERING COMPANY 10408 GREENBRIAR PL., OKLA. CITY OK. 73159 PH. 691-3213 FAX 691-3214 CA. #74 EXPIRES 06/30/2016	ABUTMENT NO. 1		DESIGN		U.S. 277 OVER DEEP RED CREEK OVERFLOW	COTTON COUNTY	
	DRAWN		CHECKED		BRIDGE "C"		
	APPROVED		ABUTMENT DETAILS (2 OF 8)				
	SQUAD		G/K ENGR.	JOB PIECE NO.	28036(04)	SHEET NO. 74	