

DESCRIPTION	REVISIONS	DATE

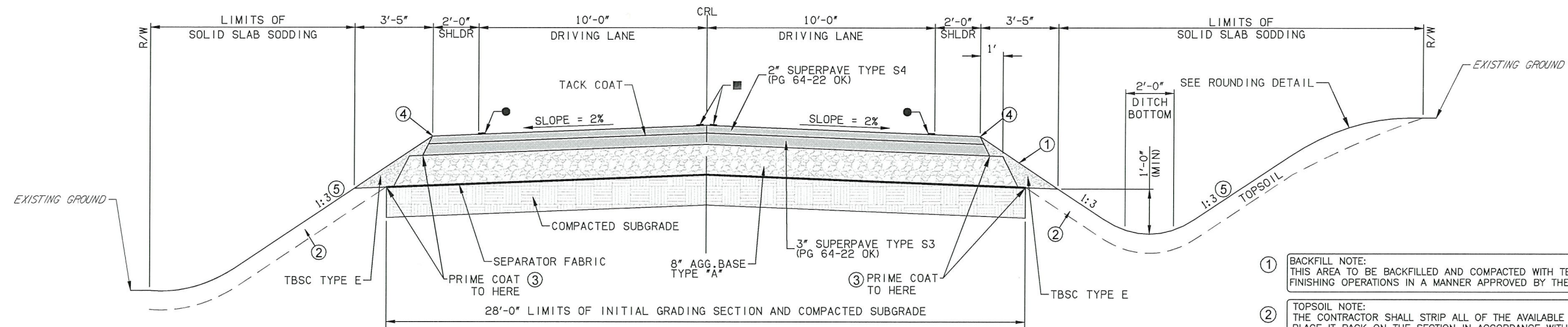

RECONSTRUCTION TYPICAL SECTION

Not To Scale
STA. 225+80 TO STA. 260+50

- ① BACKFILL NOTE:
THIS AREA TO BE BACKFILLED AND COMPACTED WITH TBSC, TYPE E AS PART OF THE FINISHING OPERATIONS IN A MANNER APPROVED BY THE ENGINEER.
- ② TOPSOIL NOTE:
THE CONTRACTOR SHALL STRIP ALL OF THE AVAILABLE TOPSOIL, STOCKPILE IT, AND PLACE IT BACK ON THE SECTION IN ACCORDANCE WITH SECTION 205 OF THE STANDARDS SPECIFICATION. RESERVED TOPSOIL SHALL BE SPREAD FIRST ON THE COMPLETED SLOPES OF THE CUT SECTIONS AND THE REMAINDER ON COMPLETED FILL SLOPES OR OTHER PRIORITY AREAS LOCATED BY THE ENGINEER. ALL ADDITIONAL COSTS ASSOCIATED WITH OPERATION SHALL BE INCLUDED IN THE PAY ITEM FOR SALVAGED TOPSOIL, LUMP SUM.

THE GRADING LINE AS SHOWN ON THE TYPICAL IS TO THE TOP OF THE TOPSOIL. EARTHWORK QUANTITIES WERE NOT ADJUSTED FOR SALVAGED TOPSOIL AND THE TOPSOIL QUANTITY IS INCLUDED IN THE EARTHWORK SUMMARY.
- ③ PRIME COAT TO BE APPLIED TO THE SUBGRADE FOR FULL WIDTH OF STABILIZED SUBGRADE. 0.35 GAL/SY BELOW AGGREGATE BASE AND 0.25 GAL/SY ABOVE AGGREGATE BASE.
- ④ CONSTRUCT ASPHALT SAFETY EDGE AS SHOWN IN SPECIAL PROVISION 411-14.
- ⑤ SEE CROSS SECTIONS FOR VARIATIONS.

- 4" YELLOW TRAFFIC STRIPE
- 4" WHITE TRAFFIC STRIPE

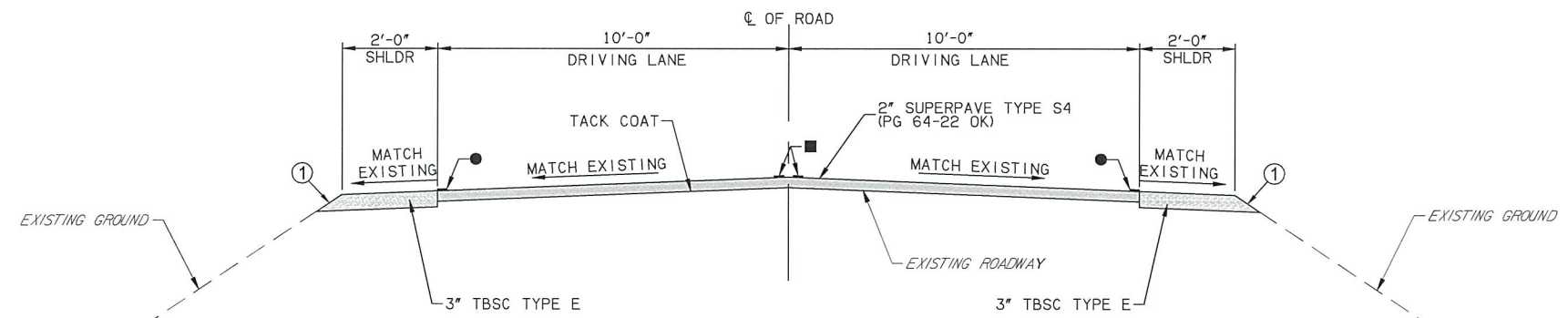

OVERLAY TYPICAL SECTION

Not To Scale
STA. 100+09.75 TO STA. 225+80

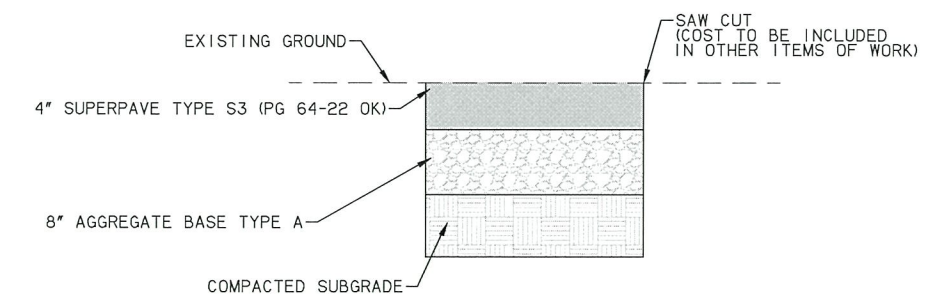

PATCHING DETAIL

Not To Scale
PATCHING TO BE USED AT THE DISCRETION OF THE ENGINEER.

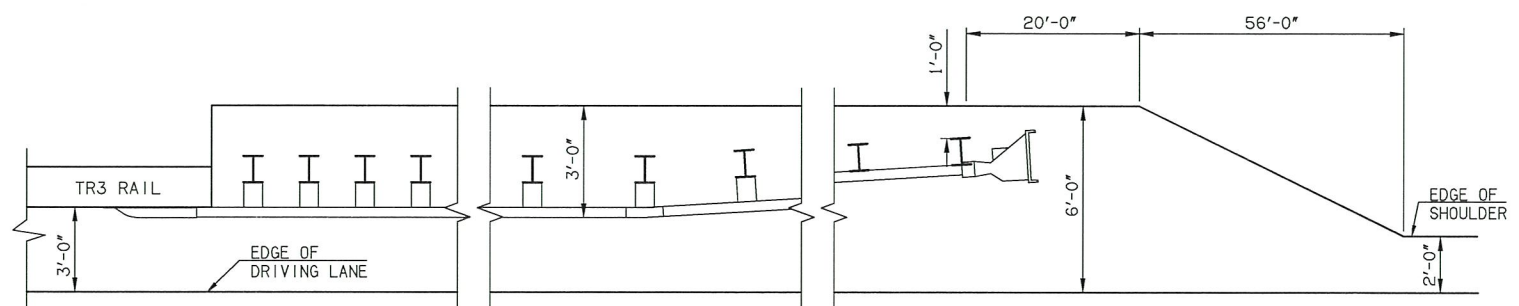

GUARDRAIL INSTALLATION DETAIL AT BRIDGES

Not To Scale

NOTE:
FOR ADDITIONAL DETAILS INCLUDING HARDWARE ELEMENTS, GUARDRAIL HEIGHT, AND POST AND BLOCK DIMENSIONS REFER TO GRH1-1-00, GRH2-1-00, GRH3-00 AND GET-2-00.

FOR STATION LIMITS SEE SHEET 7

DESIGN	RAA	12/15	OKLAHOMA DEPARTMENT OF TRANSPORTATION GUY ENGINEERING SERVICES, INC. TYPICAL SECTIONS (1) STATE JOB NO. 29394(04) SHEET NO. 2 CHEROKEE COUNTY BARRINGTON HOLLOW BR 22 & LWC
DRAWN	ALM	12/15	
CHECKED	RAP	12/15	
APPROVED	RAA	12/15	
SQUAD			

Tuesday, June 07, 2016 1:47:33 PM V:\13-828E Barrington Hollow Br 22 & LWC-Cherokee 2-CED2\CIV3D\PLANS\B28-TYPICAL SECTIONS.dwg