

TYPICAL SECTION
STA. 73+00.00 TO STA. 78+24.34

PAVEMENT REQUIREMENT		
8" PAVT. STRUCTURE	12'-0" DRIVING LANES	8'-0" PAVED SHOULDERS
SURFACE COURSE	2" SUPERPAVE TYPE S4 (PG 64-22 OK)	2" SUPERPAVE TYPE S4 (PG 64-22 OK)
BASE COURSE	2" SUPERPAVE TYPE S4 (PG 64-22 OK)	4" SUPERPAVE TYPE S4 (PG 64-22 OK)

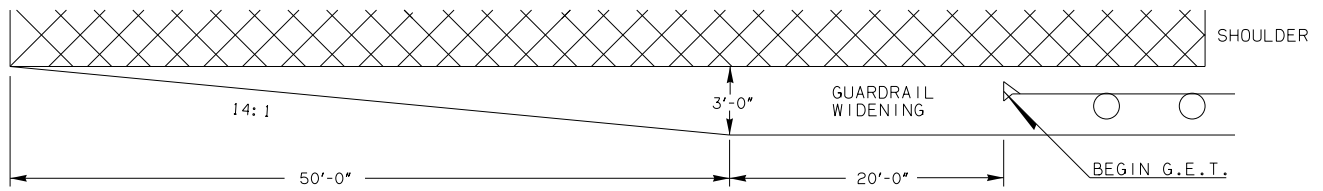

GUARDRAIL WIDENING DETAIL (NTS)

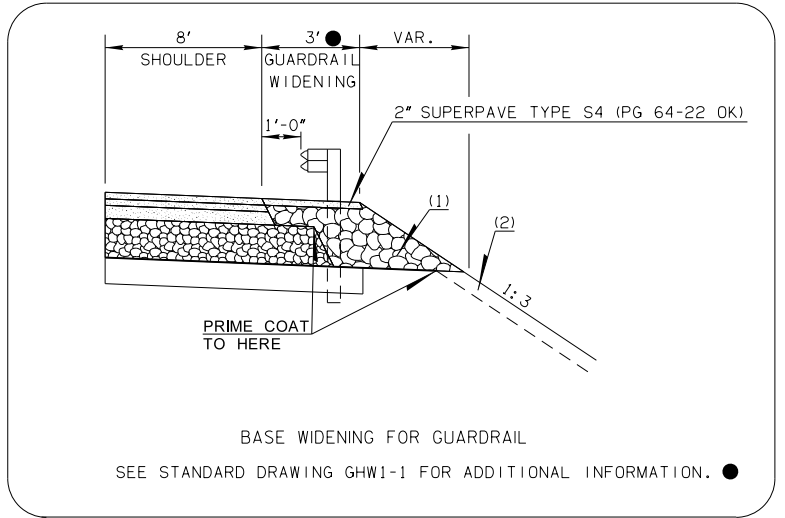
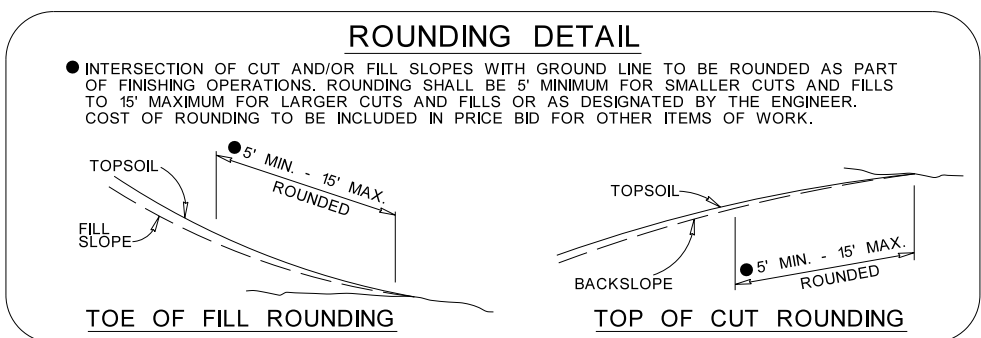

(1) BACKFILL NOTE:
TO BE BACKFILLED AS PART OF THE FINISHING OPERATIONS.
COST TO BE INCLUDED IN T.B.S.C. TYPE E.

(2) TOPSOIL NOTE:
THE CONTRACTOR SHALL STRIP ALL OF THE AVAILABLE TOPSOIL, STOCKPILE IT, AND PLACE IT BACK ON THE SECTION IN ACCORDANCE WITH SECTION 205 OF THE STANDARD SPECIFICATIONS. RESERVED TOPSOIL SHALL BE SPREAD FIRST ON THE COMPLETED SLOPES OF THE CUT SECTIONS AND THE REMAINDER ON COMPLETED FILL SLOPES OR OTHER PRIORITY AREAS LOCATED BY THE ENGINEER. ALL ADDITIONAL COSTS ASSOCIATED WITH OPERATIONS SHALL BE INCLUDED IN THE PAY ITEM FOR SALVAGED TOPSOIL, LUMP SUM.

THE GRADING LINE AS SHOWN ON THE TYPICAL AND CROSS SECTIONS IS TO THE TOP OF THE TOPSOIL. EARTHWORK QUANTITIES WERE NOT ADJUSTED FOR SALVAGE AND THE TOPSOIL QUANTITY IS INCLUDED IN THE MASS LINE BALANCE.

(3) DISTANCE MEASURED VERTICALLY FROM EDGE OF FINISHED GRADE SHOULDER.

(4) SEE CROSS SECTIONS

DESIGN	KN
DRAWN	KN
CHECKED	
APPROVED	
SQUAD	JONES

OKLAHOMA DEPARTMENT OF TRANSPORTATION
ROADWAY DESIGN DIVISION

TYPICAL SECTION

S:\DATA\STAMPS\Division 2\Projects Moved to Project Wise\Bryan 27912(04)\Draft\27912(04)-Typical.dgn