

HALF ELEVATION AT ABUTMENT

HALF ELEVATION AT PIER

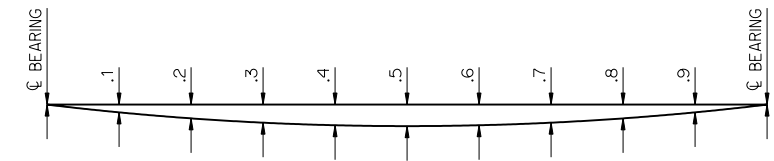

DEAD LOAD DEFLECTION DIAGRAM

BEAM SCHEDULE																					
SPAN	BEAM	BEAM LENGTH	A	STIFFENER SPACING												BEARING STIFFENER	ELASTOMERIC PAD	LFD OPERATING RATING (2)	MAXIMUM (ADTT) ₅₀ ALLOWABLE (3)		
				N1	S1	L1	S2	N3	S3	L3	N4	S4	L4	N5	S5					L5	L6
30'	W24 X 76	29'-8"	14'-3"	38	4 1/2"	14'-3"	0"	0	0"	0'-0"	0	0"	0'-0"	27	4 1/2"	10'-1 1/2"	4'-8 1/2"	PL 3/4" X 4"	3/4" X 9" X 4'-5 1/2"	HS 55.4	368
35'	W27 X 84	34'-8"	16'-9"	28	4 1/2"	10'-6"	0"	15	5"	6'-3"	15	5"	6'-3"	17	4 1/2"	6'-4 1/2"	4'-8 1/2"	PL 3/4" X 4"	3/4" X 10" X 4'-6 1/2"	HS 49.2	330
40'	W30 X 90	39'-8"	19'-3"	14	6"	7'-0"	0"	21	7"	12'-3"	23	7"	13'-5"	3	6"	1'-6"	4'-11"	PL 3/4" X 4"	3/4" X 10 3/8" X 4'-9"	HS 41.6	288
45'	W30 X 99	44'-8"	21'-9"	23	5"	9'-7"	6"	20	7"	11'-8"	20	7"	11'-8"	12	5"	5'-0"	5'-2"	PL 3/4" X 4 1/2"	3/4" X 10 1/2" X 5'-0 1/2"	HS 34.8	495
50'	W30 X 108	49'-8"	24'-3"	36	5"	15'-0"	6"	15	7"	8'-9"	15	7"	8'-9"	24	5"	10'-0"	5'-7"	PL 3/4" X 4 1/2"	3/4" X 10 1/2" X 5'-4 1/2"	HS 30.0	445

DEFLECTION SCHEDULE						
SPAN	BEAM AND DIAPHRAGM DEFLECTION					
	CL BEARING	.1 AND .9	.2 AND .8	.3 AND .7	.4 AND .6	.5
55'	0.00"	0.01"	0.01"	0.02"	0.02"	0.02"
60'	0.00"	0.01"	0.02"	0.02"	0.03"	0.03"
65'	0.00"	0.01"	0.03"	0.04"	0.04"	0.04"
70'	0.00"	0.02"	0.04"	0.06"	0.07"	0.07"
75'	0.00"	0.03"	0.06"	0.08"	0.10"	0.10"

SPAN	DECK FORMS, DECK SLAB, HAUNCH, AND TRAFFIC RAIL DEFLECTION (4)					
	CL BEARING	.1 AND .9	.2 AND .8	.3 AND .7	.4 AND .6	.5
55'	0.00"	0.08"	0.15"	0.20"	0.23"	0.25"
60'	0.00"	0.11"	0.21"	0.28"	0.33"	0.35"
65'	0.00"	0.15"	0.29"	0.39"	0.46"	0.48"
70'	0.00"	0.22"	0.42"	0.58"	0.67"	0.71"
75'	0.00"	0.31"	0.58"	0.80"	0.93"	0.98"

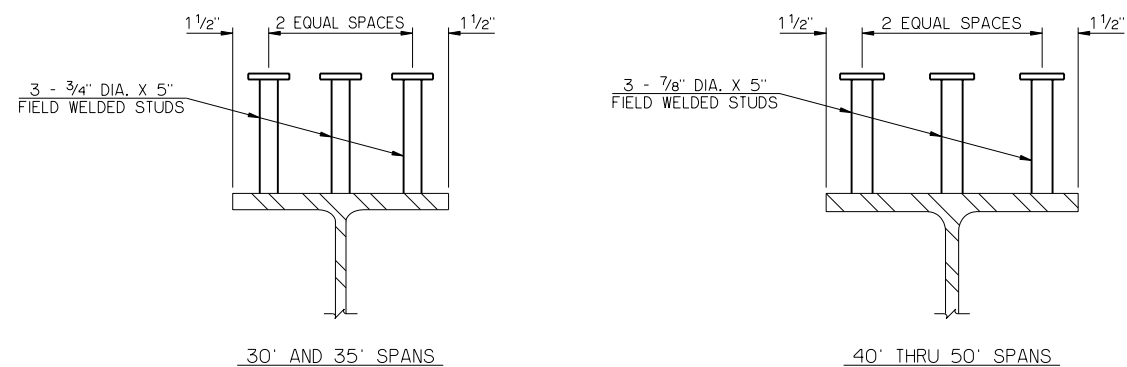

SHEAR CONNECTOR DETAILS

- ELASTOMERIC PAD SHALL HAVE A 50 DUROMETER HARDNESS AND CONSIST OF A SINGLE LAYER. THE PAD SHALL EXTEND 1/2" BEYOND THE END OF THE BEAM AS SHOWN.
- THE LFD OPERATING RATING SHOWN IN THE TABLE IS FOR THE ROLLED BEAMS ONLY AND APPLIES ONLY TO THE ROLLED BEAMS OF A BRIDGE CONSTRUCTED IN STRICT CONFORMANCE TO ALL RELEVANT DETAILS CONTAINED IN THE COMPLETE SET OF COUNTY BRIDGE STANDARDS AND TO THE ODOT STANDARD SPECIFICATIONS.
- THIS STANDARD SHALL NOT BE USED IF THE (ADTT)₅₀ EXCEEDS THE VALUE SHOWN IN THE TABLE. THE (ADTT)₅₀ IS THE NUMBER OF TRUCKS PER DAY TRAVELING THE BRIDGE IN ONE DIRECTION AVERAGED OVER A 75-YEAR DESIGN LIFE. A TRUCK IS DEFINED AS ANY VEHICLE HAVING MORE THAN EITHER TWO AXLES OR FOUR WHEELS.
- THE DEAD LOAD DEFLECTIONS SHOWN AT THE TENTH POINTS ARE THE THEORETICAL BEAM DEFLECTIONS DUE TO THE 5 PSF DECK FORM ALLOWANCE, DECK SLAB, HAUNCH AND CONCRETE TRAFFIC RAIL (TR3). THE DEAD LOAD DEFLECTIONS SHALL BE ACCOUNTED FOR IN THE HAUNCH DEPTH CALCULATIONS.

NOTES

STRUCTURAL STEEL FOR ROLLED BEAM AND ALL STIFFENER PLATES SHALL CONFORM TO AASHTO M270 (ASTM A709), GRADE 50WT2 (WEATHERING STEEL, NON-FRACTURE CRITICAL CHARPY V-NOTCH TESTED FOR ZONE 2). SHEAR CONNECTORS SHALL CONFORM TO AASHTO M169 (ASTM A108), GRADE 1015, 1018 OR 1020. WELDING SHALL HAVE WEATHERING CHARACTERISTICS.

BEAMS SHALL BE CAMBERED TO ACCOUNT FOR VERTICAL CURVE, IF NECESSARY. IF CAMBERING IS NOT REQUIRED, PLACE NATURAL CAMBER UP.

CONTRACTOR MAY ELECT TO FABRICATE PLATE GIRDERS USING EQUIVALENT PLATE SIZES IN LIEU OF ROLLED BEAM SHAPE SHOWN. WEB TO FLANGE WELDS SHALL BE MINIMUM 5/16" FILLET WELDS. NON-DESTRUCTIVE TESTING WILL BE REQUIRED AS APPROPRIATE. COSTS TO CONSTRUCT PLATE GIRDERS SHALL BE AT THE CONTRACTOR'S EXPENSE.

TERMINATE FILLET WELDS 3/8" FROM THE EDGE OF CLIPPED CORNERS OF ALL STIFFENER PLATES AND NON-CLIPPED CORNERS OF INTERMEDIATE DIAPHRAGM STIFFENERS. WRAP FILLET WELD AROUND NON-CLIPPED CORNERS OF BEARING STIFFENERS.

FOR ADDITIONAL DETAILS, SEE "DIAPHRAGM DETAILS."

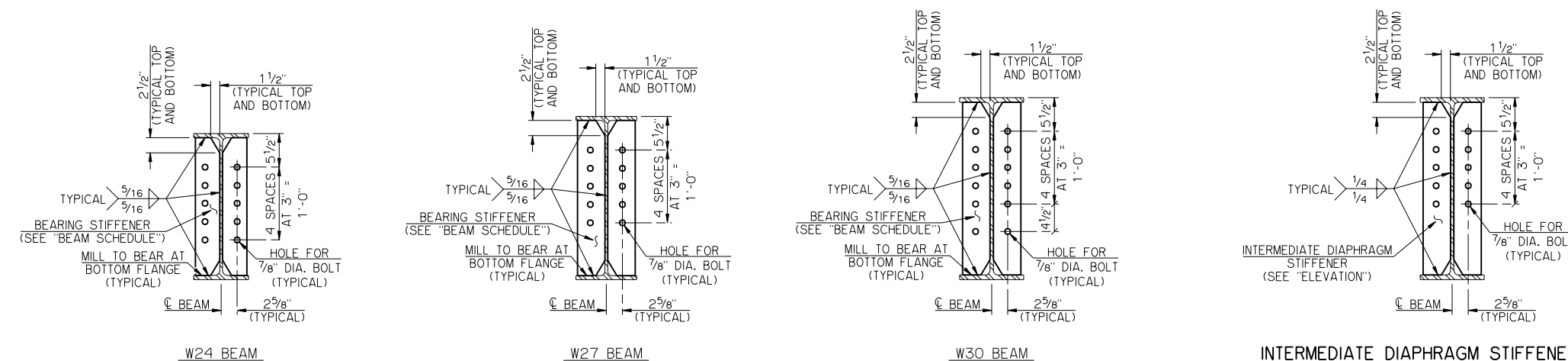

BEARING STIFFENER DETAILS

INTERMEDIATE DIAPHRAGM STIFFENER DETAIL
DETAIL SHOWN AT INTERIOR BEAM. OMIT INTERMEDIATE DIAPHRAGM STIFFENERS AT OUTSIDE FACE OF EXTERIOR BEAMS.

DETAILS SHOWN AT PIER END OF INTERIOR BEAM. OMIT BOLT HOLES ONLY IN BEARING STIFFENERS AT OUTSIDE FACE OF EXTERIOR BEAMS AND AT ABUTMENT END OF ALL BEAMS.

APPROVED BY BRIDGE ENGINEER *Robert J. Rusk* DATE 10/16/08
 OKLAHOMA DEPARTMENT OF TRANSPORTATION
 COUNTY BRIDGE STANDARD (ENGLISH)
ROLLED BEAM DETAILS
30' THRU 50' SPANS
 26' CLEAR ROADWAY - INTEGRAL - SKEWED 0°
 1999 STANDARD SPECIFICATIONS CB26-I-SKO-RB-3050 OOE
 CB-461E