

PLAN

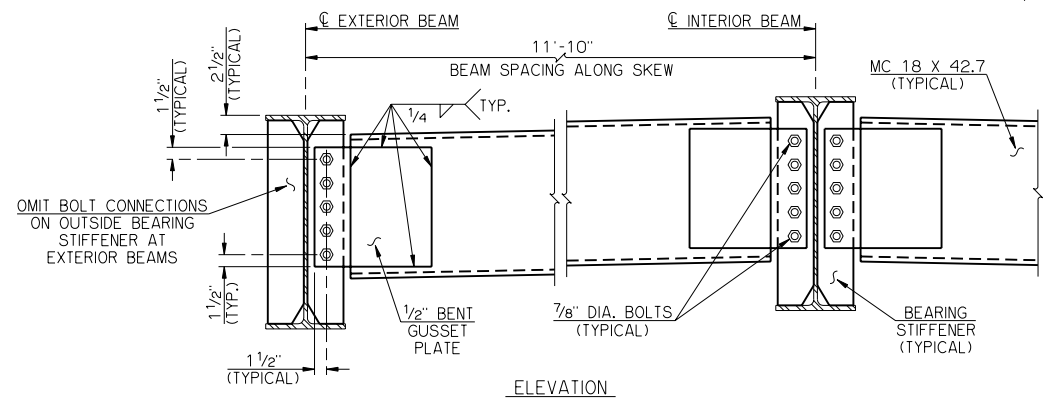

ELEVATION

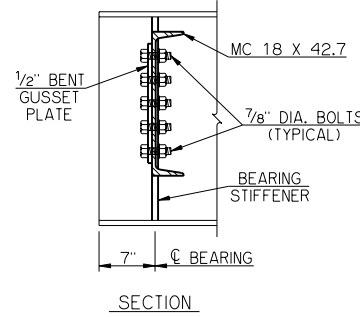

SECTION

END DIAPHRAGM DETAILS FOR W24 AND W27 BEAMS

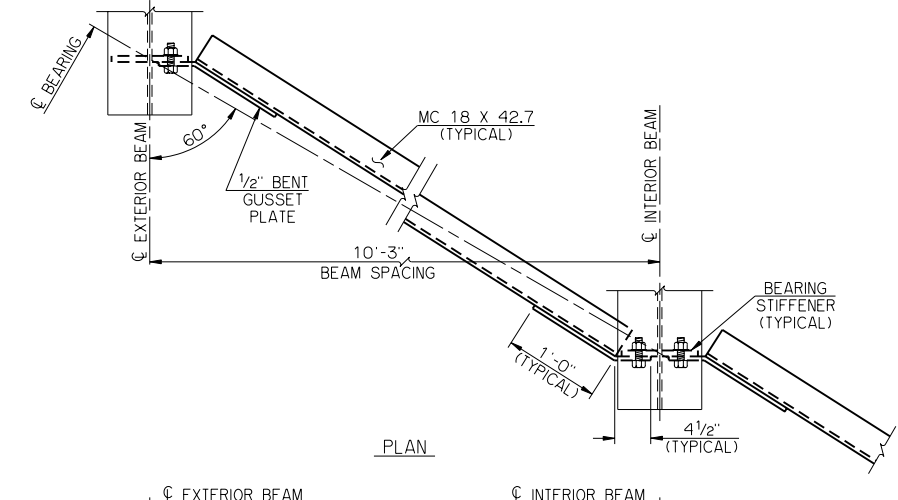

PLAN

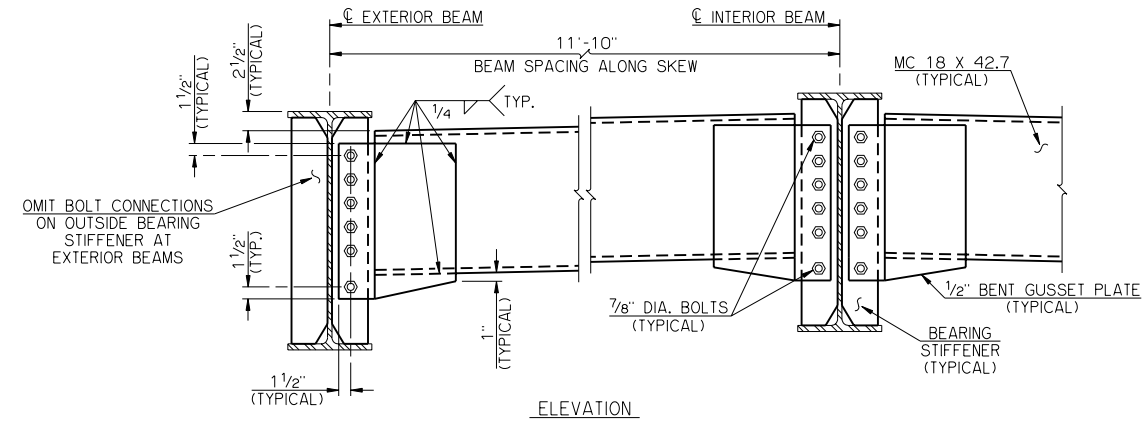

ELEVATION

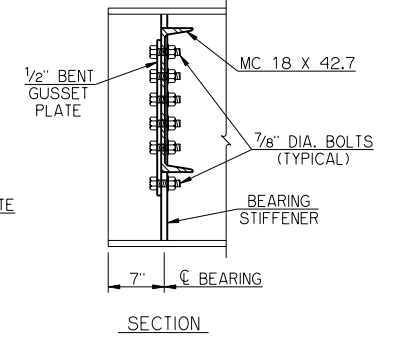

SECTION

END DIAPHRAGM DETAILS FOR W30 BEAMS

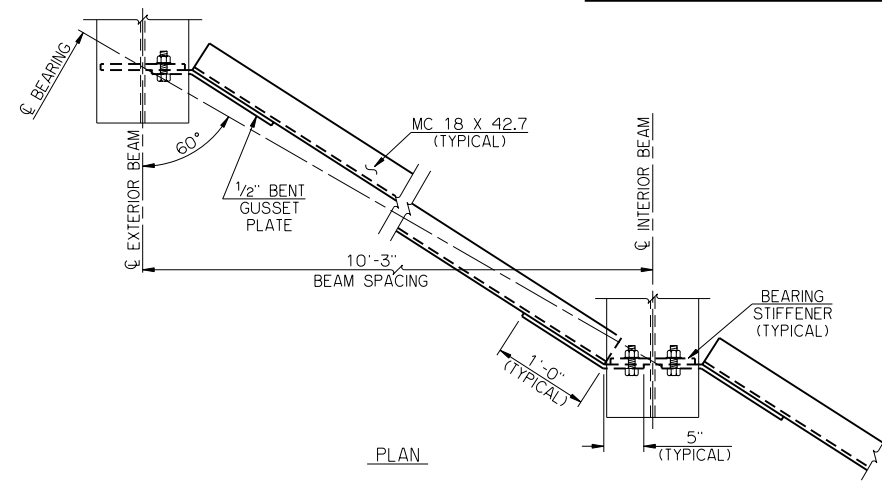

PLAN

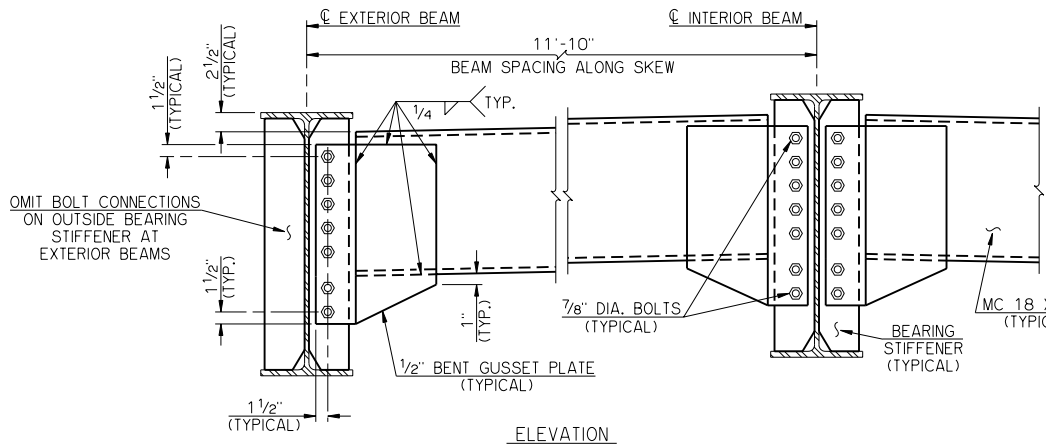

ELEVATION

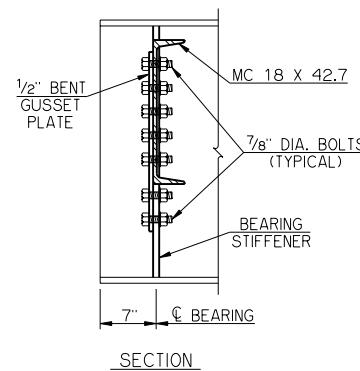

SECTION

END DIAPHRAGM DETAILS FOR W33 BEAMS

NOTES

PLAN VIEWS SHOWN WITH LEFT FORWARD SKEW, RIGHT FORWARD SKEW WILL BE OPPOSITE HAND.

CONTRACTOR MAY ELECT TO FABRICATE A BENT PLATE DIAPHRAGM IN LIEU OF CHANNEL AND GUSSET PLATE. PLATE SHALL BE 1/2" MINIMUM THICKNESS AND FORMED IN THE SHAPE OF CHANNEL WITH MINIMUM 4" FLANGES. DEPTH OF BENT PLATE DIAPHRAGM SHALL BE EQUAL TO OR GREATER THAN THAT SHOWN FOR COMBINED CHANNEL AND GUSSET PLATE. COST TO CONSTRUCT BENT PLATE DIAPHRAGM SHALL BE AT CONTRACTOR'S EXPENSE.

STRUCTURAL STEEL FOR CHANNEL DIAPHRAGMS AND GUSSET PLATES SHALL CONFORM TO AASHTO M270 (ASTM A709), GRADE 50W (WEATHERING STEEL, CHARPY V-NOTCH TESTING NOT REQUIRED). BOLTS SHALL CONFORM TO AASHTO M164 (ASTM A325). ALL BOLTS, NUTS, WASHERS AND WELDING SHALL HAVE WEATHERING CHARACTERISTICS.

APPROVED BY BRIDGE ENGINEER	<i>Robert A. Rusch</i>	DATE	10/16/05
OKLAHOMA DEPARTMENT OF TRANSPORTATION COUNTY BRIDGE STANDARD (ENGLISH)			
END DIAPHRAGM DETAILS ROLLED BEAMS (SHEET NO. 1 OF 2)			
26' CLEAR ROADWAY - CONVENTIONAL - SKEWED 30°			
1999 STANDARD SPECIFICATIONS	CB26-C-SK30-DIA-END-RB-1	OOE	CB-242E