

HALF SECTION AT END DIAPHRAGM

HALF SECTION AT INTERMEDIATE DIAPHRAGM

TYPICAL CROSS SECTION

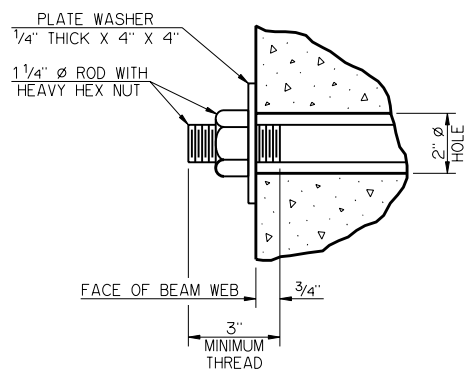

DETAIL "A"

STRUCTURAL STEEL FOR DIAPHRAGM RODS AND PLATE WASHERS SHALL CONFORM TO AASHTO M270 (ASTM A709), GRADE 50W (WEATHERING STEEL, CHARPY V-NOTCH TESTING NOT REQUIRED). A #10 REINFORCING BAR CONFORMING TO AASHTO M31, GRADE 60, AND THREADED AT THE ENDS AS SHOWN MAY BE SUBSTITUTED FOR THE DIAPHRAGM ROD. HEX NUTS SHALL CONFORM TO AASHTO M291 (ASTM A563). PAINT EXPOSED DIAPHRAGM ROD, PLATE WASHER, AND HEX NUT WITH TWO (2) COATS OF ZINC-RICH PAINT (6 MIL MINIMUM THICKNESS) AFTER ASSEMBLY. ALL COST OF DIAPHRAGM ROD, PLATE WASHER AND HEX NUT TO BE INCLUDED IN UNIT PRICE BID PER POUND OF "STRUCTURAL STEEL."

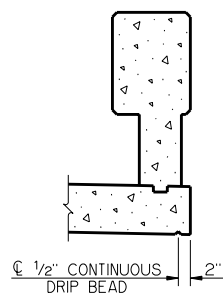

DETAIL "B"

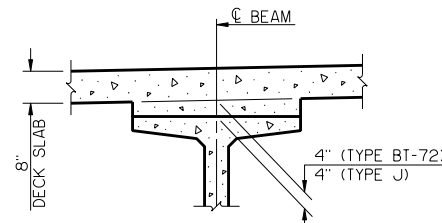

DETAIL OF HAUNCH

PLAN QUANTITIES FOR "CLASS AA CONCRETE" INCLUDE HAUNCHES OVER BEAMS. HAUNCH HEIGHT SHOWN IS AT CENTERLINE BEARING ONLY, MEASURED FROM BOTTOM OF DECK SLAB TO TOP OF BEAM, AND VARIES ACROSS THE SPAN. HAUNCH HEIGHT TO BE DETERMINED AFTER ERECTION OF BEAMS TO PROVIDE FOR DEAD LOAD DEFLECTION AND GRADE ADJUSTMENT, BUT THE PAY QUANTITY WILL BE AS SHOWN IN THE PLANS.

NOTES

ROTATE HOOKS ON AC BARS TO MAINTAIN MINIMUM CLEARANCE.  
DO NOT PLACE THE CONCRETE FOR THE DECK SLAB OR APPLY OTHER MASSIVE LOADS TO THE BEAMS, INTERMEDIATE DIAPHRAGMS OR END DIAPHRAGMS UNTIL THE CONCRETE IN THE INTERMEDIATE AND END DIAPHRAGMS HAS BEEN IN PLACE A MINIMUM OF 10 DAYS OR AT THE DISCRETION OF THE ENGINEER. THIS TIME MAY BE SHORTENED IF THE CONCRETE HAS ATTAINED 80% OF THE SPECIFIED COMPRESSIVE STRENGTH.

STAY-IN-PLACE STEEL DECK FORMS MAY BE USED IF THE MINIMUM DECK SLAB THICKNESS OF 8" IS OBTAINED BY MEASURING FROM THE TOP OF THE DECK SLAB TO THE TOP PORTION OF THE STEEL CORRUGATION. NO ADDITIONAL CONCRETE WEIGHT OF THE DECK SLAB IS PERMITTED. ADDITIONAL STEEL OF THE DECK FORMS SHALL NOT EXCEED 5 PSF. STAY-IN-PLACE PRESTRESSED CONCRETE DECK FORMS MAY BE USED IF THE FOLLOWING CONDITIONS ARE MET:  
1) SHOP DRAWINGS AND STRUCTURAL CALCULATIONS FOR THE FORMS ARE SUBMITTED TO THE BRIDGE ENGINEER FOR APPROVAL.  
2) A NEW STRUCTURAL DESIGN, STRUCTURAL CALCULATIONS, AND A NEW REINFORCING SCHEDULE FOR THE DECK SLAB ARE SUBMITTED TO THE BRIDGE ENGINEER FOR APPROVAL.  
3) SHOP DRAWINGS, NEW DECK SLAB REINFORCING SCHEDULE AND STRUCTURAL DESIGNS AND CALCULATIONS SHALL BE PREPARED BY AND SEALED BY A PROFESSIONAL ENGINEER REGISTERED IN THE STATE OF OKLAHOMA.  
ALL COSTS ASSOCIATED WITH THE USE OF STAY-IN-PLACE FORMS, INCLUDING ALL PROFESSIONAL SERVICES, MATERIAL, LABOR, EQUIPMENT AND INCIDENTALS, SHALL BE AT THE CONTRACTOR'S EXPENSE. FOR ADDITIONAL INFORMATION CONCERNING THE USE OF STAY-IN-PLACE FORMS, SEE SECTION 502 OF THE STANDARD SPECIFICATIONS.

THE DECK SLAB SHALL BE POURED ONE SPAN AT A TIME. A SPAN ADJACENT TO A FIXED PIER SHALL NOT BE POURED UNTIL AT LEAST 48 HOURS AFTER THE POUR OF ANY ADJACENT SPAN HAS BEEN COMPLETED.

CONSTRUCTION JOINTS AT THE FIXED PIERS SHALL NOT BE KEYED. IN THE EVENT OF AN EMERGENCY, POURING OF THE DECK SLAB MAY BE HALTED WITH A CONSTRUCTION JOINT MADE PERPENDICULAR TO THE DIRECTION OF TRAFFIC AS DIRECTED BY THE ENGINEER. ALL LONGITUDINAL REINFORCING STEEL SHALL BE CONTINUOUS THROUGH ALL CONSTRUCTION JOINTS. NO HEAVY EQUIPMENT WILL BE PERMITTED ON THE FINISHED DECK SLAB WITHIN 5'-0" OF ANY CONSTRUCTION JOINT UNTIL THE DECK SLAB IS IN PLACE ON BOTH SIDES OF THE RESPECTIVE JOINT.

DO NOT TIE WITHIN 6" OF ANY CONSTRUCTION JOINT.

FOR BAR LIST AND DETAILS OF BENT REINFORCING STEEL, SEE DECK SLAB BAR LIST.

FOR LFD OPERATING RATING AND DEAD LOAD DEFLECTION DIAGRAM, SEE P.C. BEAM DETAILS.

APPROVED BY BRIDGE ENGINEER *Debra J. Rusch* DATE 10/16/05  
OKLAHOMA DEPARTMENT OF TRANSPORTATION  
COUNTY BRIDGE STANDARD (ENGLISH)  
TYPICAL CROSS SECTION  
TYPE BT-72 AND TYPE J P.C. BEAMS  
26' CLEAR ROADWAY - CONVENTIONAL - SKEWED 0°  
1999 STANDARD SPECIFICATIONS CB26-C-SKO-XSECT-PC5 OOE  
CB-165E