

PILE SCHEDULE	
SPAN	MAXIMUM FACTORED PILE LOAD
110'	80.3 TON
115'	82.3 TON
120'	84.3 TON
125'	86.3 TON
130'	88.2 TON
135'	90.2 TON

PEDESTAL DIMENSIONS		
BEAM TYPE	P1	P2
TYPE BT-72	2"	4 7/16"
TYPE J	2 1/2"	4 15/16"

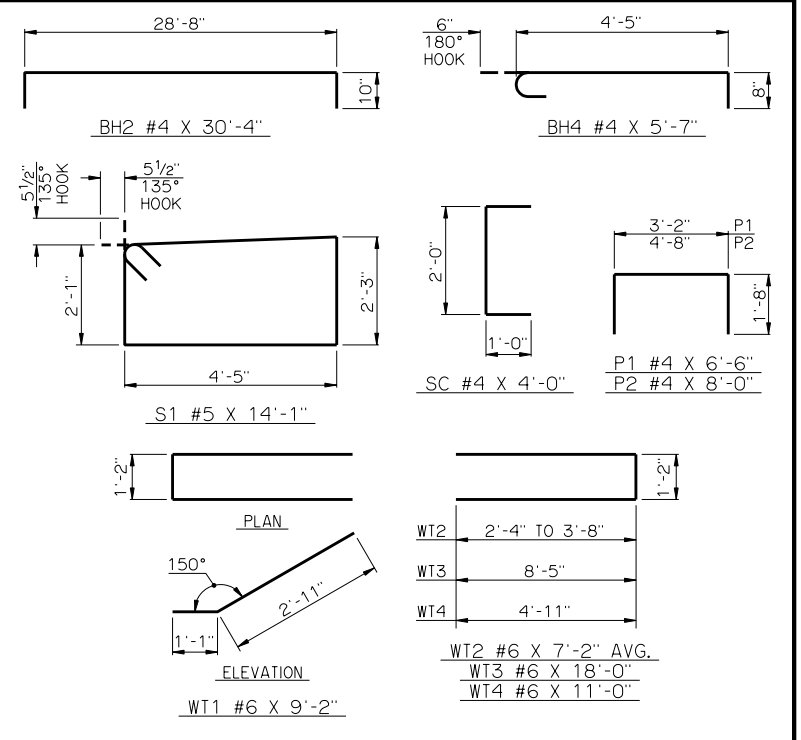
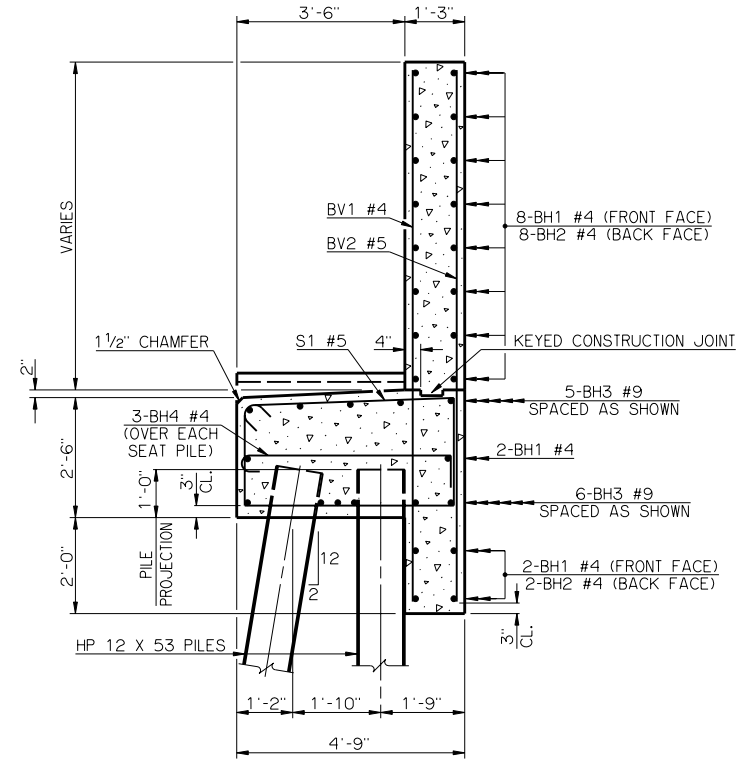

BAR LIST - ONE ABUTMENT					
MARK	NO.	SIZE	FORM	LENGTH	LENGTH VARIATION
BH1	12	#4	STR.	28'-8"	-
BH2	10	#4	BNT.	30'-4"	-
BH3	11	#9	STR.	28'-8"	-
BH4	27	#4	BNT.	5'-7"	-
BV1	30	#4	STR.	10'-10" AVG.	10'-8" TO 11'-0"
BV2	30	#5	STR.	10'-10" AVG.	10'-8" TO 11'-0"
P1	18	#4	BNT.	6'-6"	-
P2	12	#4	BNT.	8'-0"	-
S1	36	#5	BNT.	14'-1"	-
SC	6	#4	BNT.	4'-0"	-
WT1	2	#6	BNT.	9'-2"	-
WT2	4	#6	BNT.	7'-2" AVG.	5'-10" TO 8'-6"
WT3	8	#6	BNT.	18'-0"	-
WT4	18	#6	BNT.	11'-0"	-

③ NO. INCLUDES TWO SETS OF 15 BARS
④ NO. INCLUDES TWO SETS OF 2 BARS

SUMMARY OF QUANTITIES - ONE ABUTMENT ⑤		
ITEM	UNIT	TOTAL
SUBSTRUCTURE EXCAVATION COMMON	CY	65.00
GRANULAR BACKFILL	CY	60.00
CLASS A CONCRETE	CY	25.60
REINFORCING STEEL	LB	3,440.00
PILES, FURNISHED (HP 12 x 53)	LF	-
PILES, DRIVEN (HP 12 x 53)	LF	-
6" PERFORATED PIPE UNDERDRAIN ROUND	LF	26.00
6" NON-PERF. PIPE UNDERDRAIN RND.	LF	-

⑤ EXCLUDES WINGS

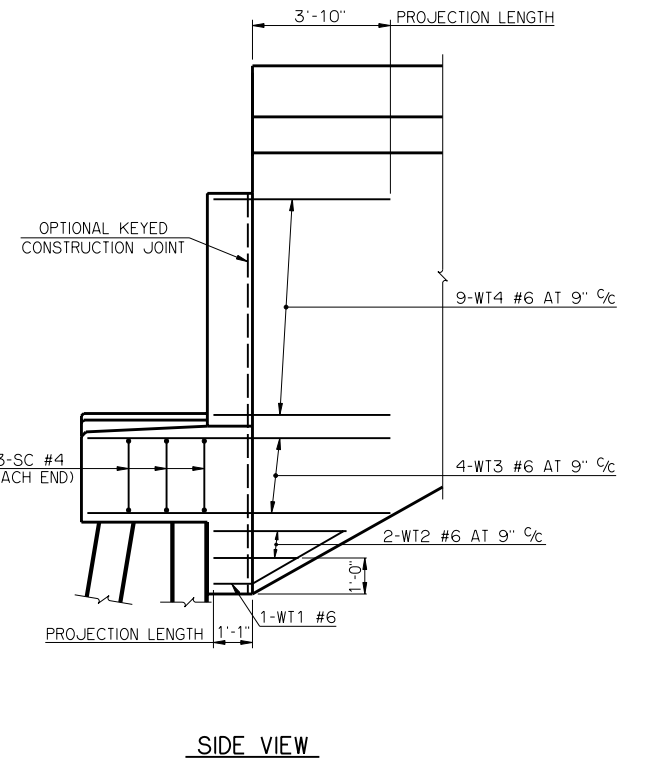
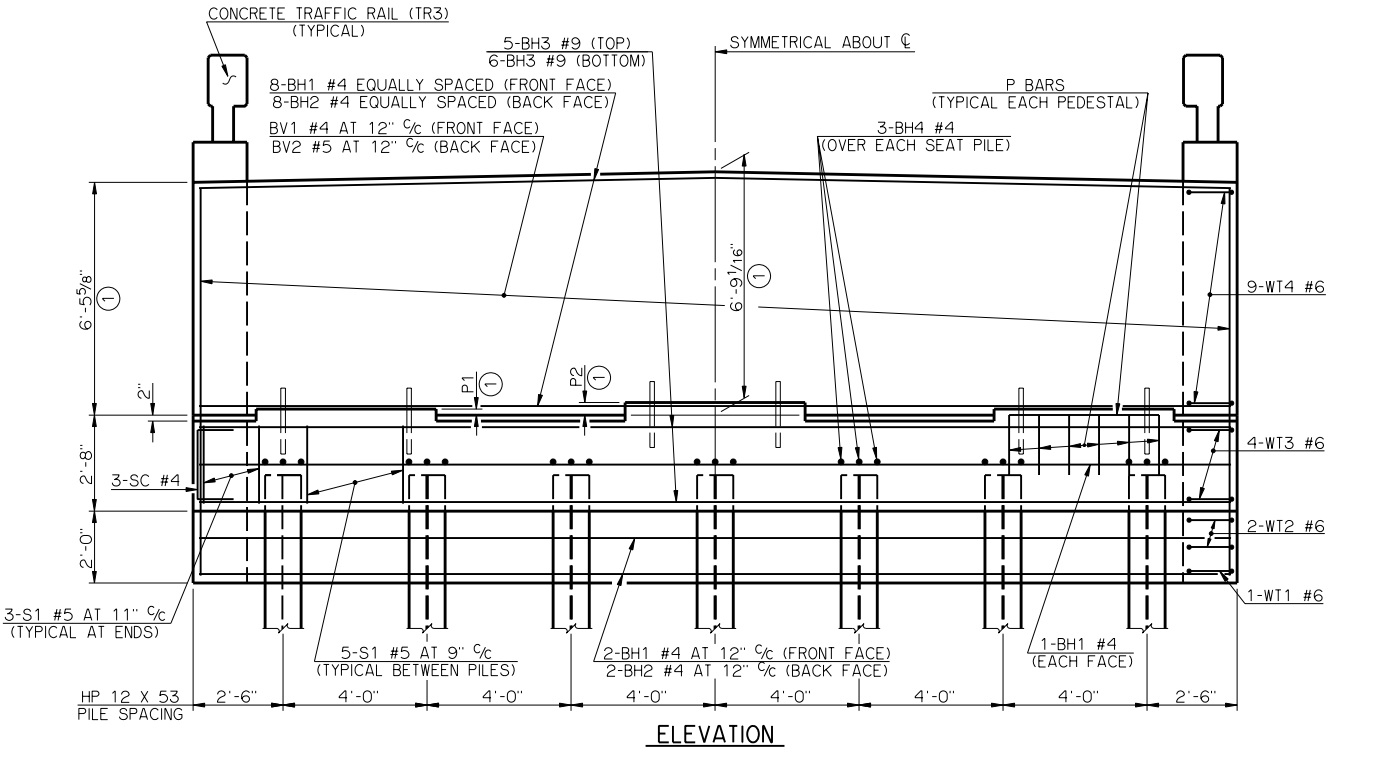

① DIMENSIONS ARE FROM TOP OF BRIDGE SEAT AT FRONT FACE OF BACKWALL.
② ALL WT WING REINFORCING STEEL TIED TO THE ABUTMENT BRIDGE SEAT, BACKWALL AND CURTAIN WALL REINFORCING STEEL MUST BE IN PLACE PRIOR TO POURING ABUTMENT CONCRETE. FOR ADDITIONAL INFORMATION SEE WING DETAILS.

APPROVED BY BRIDGE ENGINEER *Robert J. Rusch* DATE 10/16/08
OKLAHOMA DEPARTMENT OF TRANSPORTATION
COUNTY BRIDGE STANDARD (ENGLISH)
ABUTMENT DETAILS
TYPE BT-72 AND TYPE J P.C. BEAMS
26' CLEAR ROADWAY - CONVENTIONAL - SKEWED 0°
1999 STANDARD SPECIFICATIONS CB26-C-SKO-ABUT-PC5 OOE CB-153E